

Operating and assembly instructions

Permanent magnetic couplings



CONTENT

1. General	4	6. Transport, storage, return and disposal	21
1.1 Basic principles	4	6.1 Transport	21
1.2 Personnel qualification and training	4	6.2 Storage	21
1.3 Safety symbols	4	6.3 Return	21
2. Notes	5	6.4 Disposal	21
2.1 Permissible modes of operation	5	7. Explosion protection	22
2.2 Dangers arising from non-observance of the operating and assembly instructions	5	7.1 Labeling	22
2.3 Safety awareness	5	7.2 Temperature monitoring / limits	23
2.4 Safety instructions for the user	5	7.3 Materials in explosive areas	24
2.5 Safety instructions for inspection, maintenance and assembly work	5	7.4 Protective measures of the ignition sources	24
2.6 Unauthorized modification and spare parts production ..	5	8. Glossary	25
2.7 EC Machinery Directive 2006/42/EC	6	9. Certificate of conformity	26
2.8 Notes about the magnetic field	6	10. Example: IATA certificate	28
3. Description of the permanent magnetic coupling ..	6	11. Clearance certificate	29
3.1 Working principle	6		
3.2 Components – permanent magnetic coupling	6		
3.2.1 Extension by a SSiC plain bearing	7		
4. Assembly	8		
4.1 Permanent magnetic coupling	8		
4.1.1 Assembling the inner rotor	9		
4.1.2 Assembling the canister	9		
4.1.2.1 Assembling the canister made of borosilicate	10		
4.1.2.2 Assembling the canister made of CFRP and PTFE-inliner	10		
4.1.2.3 Assembling the canister made of PEEK	10		
4.1.2.4 Assembling the canister made of ceramic	11		
4.1.3 Assembling the outer rotor	11		
4.2 Permanent magnetic coupling with SSiC plain bearing	12		
4.2.1 Pre-assembly of the inner rotor	13		
4.2.2 Pre-assembly of the SSiC plain bearing onto the output shaft	13		
4.2.3 Assembly of the SSiC plain bearing with inner rotor and output side	13		
4.3 Mounting aids/forced guides	14		
4.4 Permissible deviations in assembly	15		
4.5 Screw tightening torques	16		
4.6 Disassembly	17		
5. Comissioning/operation	17		
5.1 Temperature limits	17		
5.2 Pressure ranges	18		
5.3 Lubrication of the SSiC plain bearings	19		
5.4 Losses during operation	19		
5.4.1 Eddy current losses	19		
5.4.2 Hydraulic friction losses	19		
5.5 Maintenance	19		
5.6 Malfunctions: Causes and elimination	20		

LIST OF FIGURES

Figure 1:	Permanent magnetic coupling	6
Figure 2:	Permanent magnetic coupling with SSiC plain bearing	7
Figure 3:	Gap clearance of SSiC plain bearing	7
Figure 4:	Position and designation of the components of a permanent magnetic coupling.	8
Figure 5:	Mounting the inner rotor to the output side (A1)	9
Figure 6:	Basic canister assembly/sealing on a flange for technically tight systems (A4)	9
Figure 7:	Standard canister made of metal (2)	9
Figure 8:	Components/assembly canisters made of borosilicate (A2)	10
Figure 9:	Components/assembly canisters made of CFRP with PTFE inliner (A2)	10
Figure 10:	Components/assembly canisters made of PEEK (A2)	10
Figure 11:	Components/assembly canisters made of ceramic (A2)	11
Figure 12:	Mounting the outer rotor to the drive side (optional) (A3)	11
Figure 13:	Mounting the outer rotor to the drive side (A5)	11
Figure 14:	Overview of permanent magnetic coupling with SSiC plain bearing	12
Figure 15:	Components of the SSiC plain bearing	12
Figure 16:	Mounting axial bearing bracket I with inner rotor (A6)	13
Figure 17:	Mounting the SSiC plain bearing to the output shaft (A7)	13
Figure 18:	Assembly of the SSiC plain bearing with the inner rotor and the output side (A8)	13
Figure 19:	Example of a mounting aid	14
Figure 20:	Permissible deviations in assembly	15
Figure 21:	Screw tightening sequence	16
Figure 22:	Temperature monitoring example	23

LIST OF TABLES

Table 1:	Meaning of permanent magnetic coupling designation.	6
Table 2:	Standard clearance of SSiC plain bearing	7
Table 3:	Tightening torque for standard fastening screws	16
Table 4:	Temperature limits for DST standard and high temperature magnets.	17
Table 5:	Temperature limits for different canister materials	18
Table 6:	Overview of the pressurization of canisters	18
Table 7:	Causes of malfunctions and their elimination	20
Table 8:	Classification of maximum surface temperatures for Group II equipment according to ISO 80079-36	23
Table 9:	Temperature classes for different canister material in explosive atmospheres	23
Table 10:	Predominant use of materials in explosive areas	24
Table 11:	Ignition sources and their protective measures	24

IMPRINT

Operating and assembly instructions DST permanent magnetic couplings und conversion kits according to EN 62079
Translation
DST Dauermagnet-SystemTechnik GmbH

The current publication of this operation and assembly instruction supersedes all information from previous publications. DST reserves the right to make changes and substitutions. DST is not liable for any printing errors. Reproduction, including excerpts, is permitted only after written approval by DST. DST reserves the right to modify technical data at any time. Last revised: 10/2022

1. GENERAL

The basic advice given in these operating and assembly instructions on assembly/installation, operation and maintenance is a prerequisite for safe handling of the coupling and prevents damage to property and personal injury.

The permanent magnetic coupling may only be used under the operating conditions listed in the referenced documents. All other operating conditions which are not listed in the technical documentation must be agreed with DST before commissioning.

1.1 Basic principles

Drawing numbers, article numbers and the order number are listed in the order confirmation.

The drawing number, article number and order number clearly identify the permanent magnetic coupling and provide identification in all further business processes.

1.2 Personnel qualification and training

The personnel for operation, maintenance, inspection and assembly must have the appropriate qualifications for this work. Areas of responsibility, competencies and supervision of the personnel must be precisely regulated by the user.

1.3 Safety symbols

Caution

This signal word indicates a danger. If it is not observed, functional errors and machine damage can be expected.



Warning

This signal word indicates a possible endangerment with medium risk, which can result in death or (severe) bodily injury if not avoided.



Danger

This signal word indicates an immediate threat with high risk, which will result in death or serious bodily injury if it is not avoided.

It is essential to comply with the safety instructions in these operating and assembly instructions.

The operating and assembly instructions must be always accessible.

The user is responsible for all local regulations and their compliance. These are not listed in the operating and assembly instructions.

Please inform DST immediately about the damage in order to preserve the warranty claims in case of damage.

Please observe section 4 for the assembly/disassembly of individual components supplied by DST.



This symbol provides you with information on protection against explosions in potentially explosive atmospheres, in accordance with EU Directive 2014/34/EU (ATEX).



This symbol in combination with the signal word "Danger" indicates hazards which are related to magnetic fields and also indicates protection against the magnetic fields.

2. NOTES



All indications listed in this section imply a danger with a high degree of risk.

2.1 Permissible modes of operation

The permanent magnetic coupling may only be used under the operating conditions specified in the applicable documents.

The permanent magnetic coupling may only be operated when completely assembled and in a technically perfect condition. The permanent magnetic coupling is mainly suitable for a soft start (starting mode) of the motor! In case of a direct start of the motor, please contact DST in advance.

2.2 Dangers arising from non-observance of the operating and assembly instructions

- Failure of important functions of the permanent magnetic coupling.
- Danger to personnel due to electrical, mechanical or thermal effects
- Danger to personnel and the environment due to leakage of dangerous substances

2.4 Safety instructions for the user

The existing regulations for accident prevention must be observed. Hazards due to electrical energy must be excluded. VDE regulations and those of local and national power supply companies must be observed.

2.5 Safety instructions for inspection, maintenance and assembly work

Permanent magnetic couplings that convey fluids hazardous to health and the environment must be decontaminated.

- The equipment should be put out of operation and secured against unintentional start-up before inspection, maintenance and assembly work.
- The permanent magnetic coupling must have assumed the ambient temperature.
- The permanent magnetic coupling must be depressurized and emptied

2.6 Unauthorized modification and spare parts production

Modifications to the permanent magnetic coupling are only permitted after consultation and approval from DST. Original spare parts and accessories authorized by DST are used for safety

Caution

In case of non-observance of the operating and assembly instructions and the listed safety instructions, any claim for warranty and compensation expires.

The SSiC plain bearing (if used) must never be operated dry (without medium).

All other operating conditions which are not listed in the technical documentation must be agreed with DST.

2.3 Safety awareness

The safety instructions given in these operating and assembly instructions, the existing national regulations for accident prevention and any internal operating, working and safety regulations of the operator must be observed.

An on-site contact protection for hot, cold and rotating parts must be installed and its function checked. The contact protection must not be removed during operation.

Immediately after completion of the work, the safety and protective devices must be refitted, and their function checked.

purposes. The unauthorized modification or use of unauthorized spare parts void the liability of DST for the resulting consequences.

2.7 EC Machinery Directive 2006/42/EC

The permanent magnetic couplings supplied by DST are to be regarded as components, not as machines or partly completed machines within the scope of the EC Machinery Directive

2006/42/EC. Consequently, no declaration of incorporation shall be issued by DST.

2.8 Notes about the magnetic field



Strong magnetic field in the area of the magnetic coupling or with single magnets!

Danger to life for persons with pacemakers! Interference with magnetic data carriers, electronic devices, components and instruments! Uncontrolled mutual attraction of magnet-equipped individual parts, tools and such!

Safety distance to permanent magnetic couplings installed in pumps, agitators and conversion kits etc:

A safety distance of at least 2 m must be maintained for rotors and individual magnets which have not yet been installed. When installed, the magnetic field is almost completely shielded. A safety distance of at least 0.5 m must be maintained from an installed magnetic coupling for persons with pacemakers.

3. DESCRIPTION OF THE PERMANENT MAGNETIC COUPLING

3.1 Working principle

Permanent magnetic couplings are torque-actuated couplings and belong to the category of engageable couplings. These transmit the torque synchronously by means of magnetic field lines up to the maximum torque (breakaway torque) and ideally operate below the breakaway torque in synchronous operation (input speed is equal to the output speed).

With permanent magnetic couplings, the torque of the drive unit is transmitted to the output side without contact by magnetic force. The outer rotor directly transmits the drive torque of the motor to the inner rotor.

The canister is located between the permanent magnetic rotors on the drive side and output side. It serves as a hermetic seal and acts like a partition wall. Static seals (e.g. flat seals/o-rings) are required instead of dynamic shaft seals (e.g. mechanical seals, material book packings) for sealing the canister

Caution

Although the permanent magnetic coupling provides safety against overload due to slipping, it should not be used in the overload condition, as this leads to very high heat generation.

3.2 Components – permanent magnetic coupling

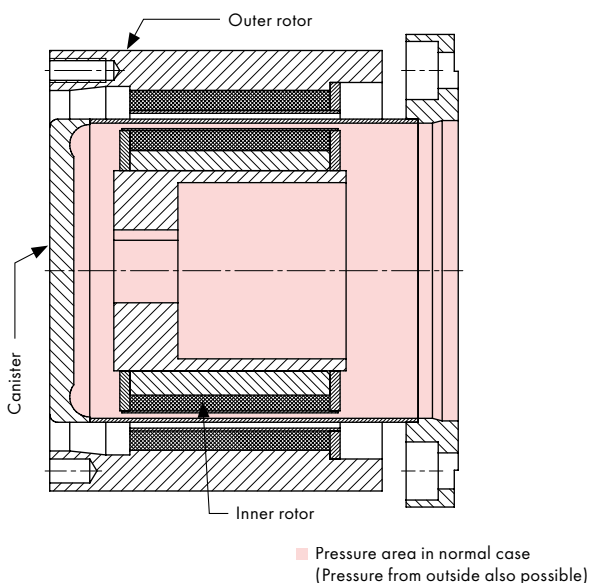

As shown in Figure 1, the permanent magnetic coupling essentially consists of the following components:

- inner rotor
- outer rotor
- canister

Labeling example: DST 110/80

Abbreviation	Meaning
DST	company name
110	series
80	rating in Nm

Figure 1: Permanent magnetic coupling

Table 1: Meaning of permanent magnetic coupling designation

3.2.1 Extension by a SSiC plain bearing

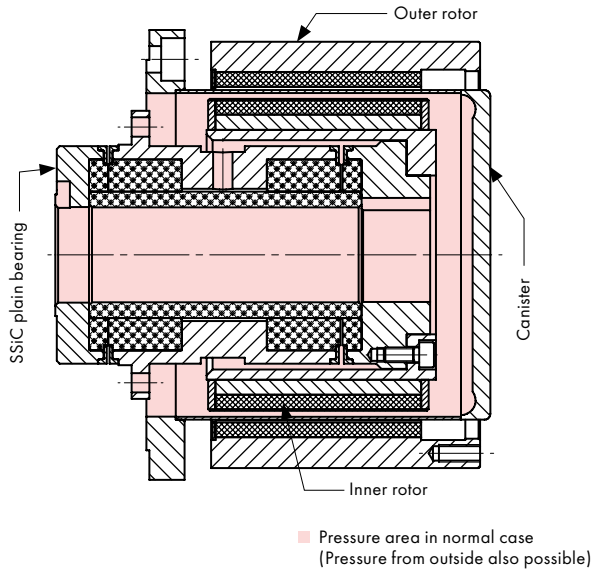

As shown in Figure 2, the permanent magnetic coupling with SSiC plain bearing consists of the following components

- inner rotor
- outer rotor
- canister
- SSiC plain bearing

The SSiC plain bearing is attached to the shaft of the output side by fitting a key connection.

The inner rotor is bolted to the SSiC plain bearing.

Figure 2: Permanent magnetic coupling with SSiC plain bearing

Axial clearance of SSiC plain bearing

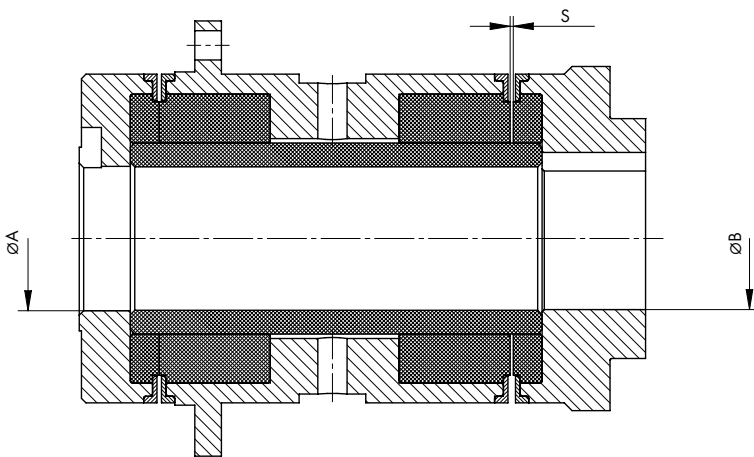

Figure 3: Gap clearance of SSiC plain bearing

Bearing	Axial clearance S [mm]	øA [mm]	øB [mm]
DST 60	0.5	11.5 G7	11 G7
DST 75	0.7	16.5 G7	16 G7
DST 100	0.7	32.5 G7	32 G7
DST 135	0.7	32.5 G7	32 G7
DST 165	0.7	40.5 F7	40 F7
DST 200	0.7	50.5 F7	50 F7

Smaller axial play also possible on request.

Table 2: Standard clearance of SSiC plain bearing

4. ASSEMBLY

Before installation, check all individual parts/assemblies for completeness and all relevant dimensions for dimensional accuracy. During assembly, observe the weight of the components – it may be necessary to use lifting equipment.

Caution

Assembly aids or tools as well as the permanent magnetic coupling components can be attracted by the magnetic field of the rotors and cause damage.

The item numbers in Roman numbers are not included in the scope of delivery and represent the adjoining components as an example.

4.1 Permanent magnetic coupling

- 1 inner rotor
- 2/A2 canister
- 3 outer rotor
- 4 motor hub
- 5 dowel pins
- 6 cap screws
- 7 set screw

(Pos. 4...7 when ordering with motor hub)

Caution



Solid magnetic particles are not permitted in the area of the permanent magnetic coupling, as they can adhere to the outer rotor and / or inner rotor, which can cause the rotor to rub against the canister and thus lead to malfunctions!

Caution

The inner and outer rotor of the permanent magnetic coupling must be bearing mounted by the customer. Depending on the load case, the mounting and bearing of the rotors on the drive side/output side (e.g.: motor, pump) may be sufficient. The permissible deviations from section 4.4 must be observed.

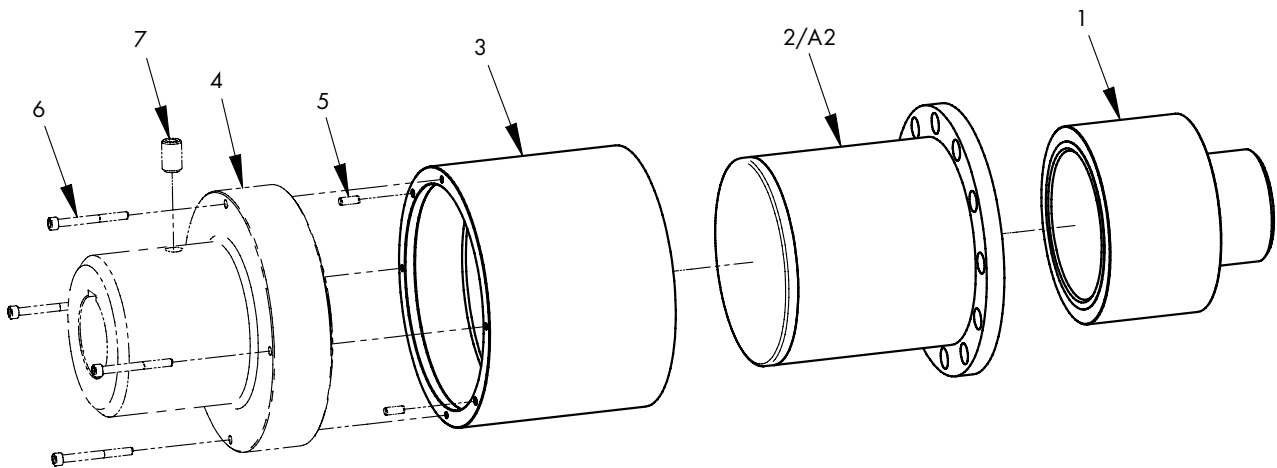

Figure 4: Position and designation of the components of a permanent magnetic coupling

4.1.1 Assembling the inner rotor

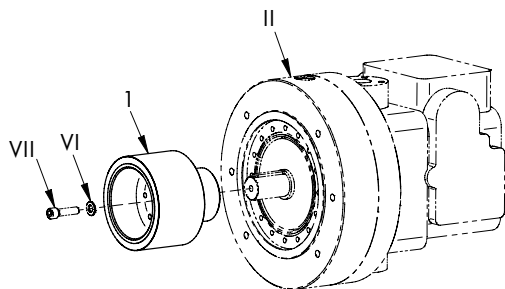

Figure 5: Mounting the inner rotor to the output side (A1)

- Push the inner rotor (1) onto the key connection of the output side (II)
- Axially screw the inner rotor (1) by using the cap screw (VII) and washer (VI) [Alternatively: secure with set screw (7), as described in section 4.1.3 Assembling the outer rotor]

4.1.2 Assembling the canister

The use of purely static seals separates the area in contact with the medium from the dry area and designates it as technically tight.

Caution

The part in contact with the medium is sealed exclusively by static seals, such as flat seals or O-rings, which are inserted in the output side. The seals must be selected to be medium and temperature-resistant.

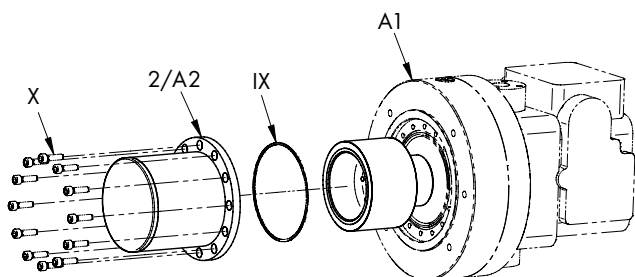

Figure 6: Basic canister assembly/sealing on a flange for technically tight systems (A4)

- Center gasket (IX) on customer-side flange (A1) (for flat gaskets). Insert O-rings in groove
- Center the canister (2/A2) on the flange (A1) and tighten with cap screws (X) (for tightening torques for screws, see 4.5)

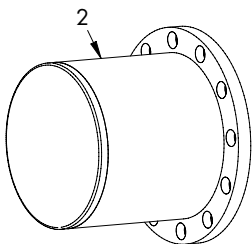

Figure 7: Standard canister made of metal (2)

- The metal canister (2) is a single component as standard
- All other canisters (A2) consist of several components (e.g.: borosilicate, CFRP with PTFE-inliner, PEEK and ceramic). The respective subsections 4.1.2.1, 4.1.2.2, 4.1.2.3 und 4.1.2.4 must be observed during assembly.

4.1.2.1 Assembling the canister made of borosilicate

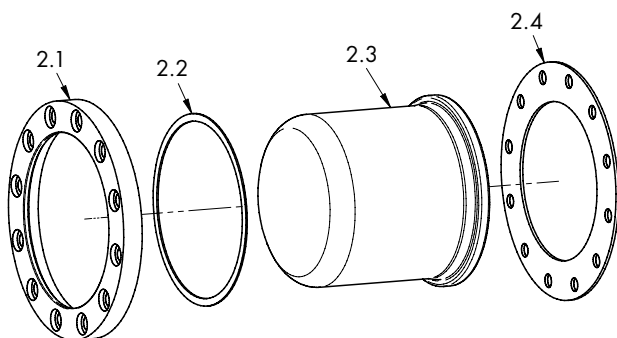

Figure 8: Components/assembly canisters made of borosilicate (A2)

- Insert centering spacer ring (2.2) into flange (2.1)
- Slide flange (2.1) with the inserted centering spacer ring (2.2) over the borosilicate canister (2.3)
- Slide the canister assembly (A2) with the flat gasket (2.4) (included in delivery) over the assembly internal rotor (A1)
- Slide the canister assembly (A2) over the internal rotor and center it in the customer-side flange
- Screw the canister assembly (A2) into the customer flange with cap screws (X) (for tightening torques for screws, see 4.5)

Caution

The borosilicate canister is fragile and must be handled with special care during handling, assembly and disassembly.

4.1.2.2 Assembling the canister made of CFRP and PTFE-inliner

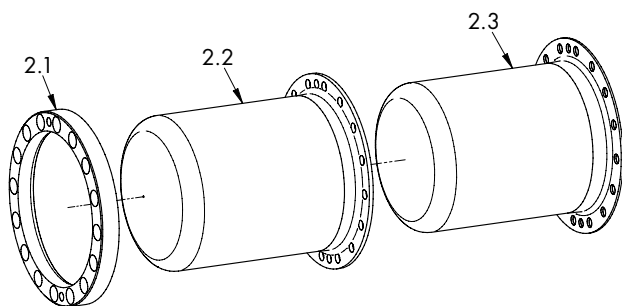

Figure 9: Components/assembly canisters made of CFRP with PTFE inliner (A2)

- Insert PTFE-inliner (2.3) into the CFRP canister (2.2)
- Slide canister flange (2.1) over CFRP canister (2.2)
- Center gasket (IX) on customer-side flange (A1) (for flat gaskets). Insert O-rings in groove
- Slide the canister assembly (A2) over the internal rotor and center it in the customer-side flange
- Screw the canister assembly (A2) into the customer flange with cap screws (X) (for tightening torques for screws, see 4.5)

4.1.2.3 Assembling the canister made of PEEK

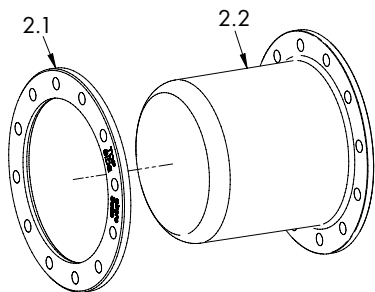

Figure 10: Components/assembly canisters made of PEEK (A2)

- Slide the flange (2.1) over the PEEK canister (2.2)
- Center gasket (IX) on customer-side flange (A1) (for flat gaskets). Insert O-rings in groove
- Slide the canister assembly (A2) over the internal rotor and center it in the customer-side flange
- Screw the canister assembly (A2) into the customer flange with cap screws (X) (for tightening torques for screws, see 4.5)

4.1.2.4 Assembling the canister made of ceramic

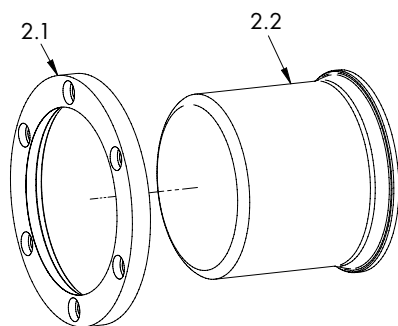

Figure 11: Components/assembly canisters made of ceramic (A2)

- Slide the flange (2.1) over the ceramic canister (2.2)
- Center gasket (IX) on customer-side flange (A1) (for flat gaskets). Insert O-rings in groove
- Slide the canister assembly (A2) over the internal rotor and center it in the customer-side flange
- Screw the canister assembly (A2) into the customer flange with cap screws (X) (for tightening torques for screws, see 4.5)

Caution

The ceramic canister is fragile and must be handled with special care during handling, assembly and disassembly.

4.1.3 Assembling the outer rotor

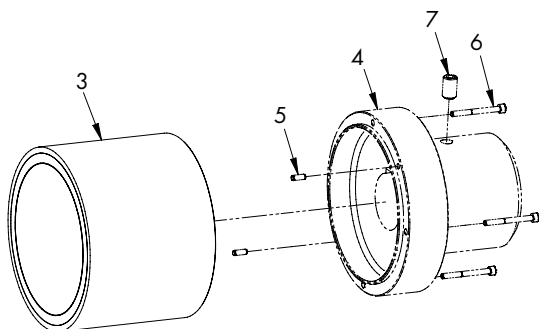

Figure 12: Mounting the outer rotor to the drive side (optional) (A3)

- Insert dowel pins (5) into the motor hub (4)
- Guide the outer rotor (3) along the dowel pins (5) and centre it in the motor hub (4)
- Screw the assembly with cap screws (6)

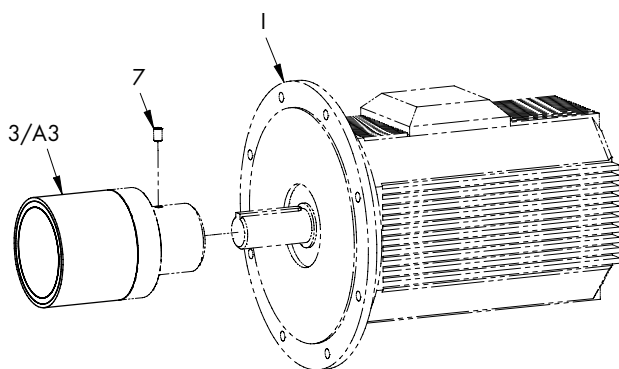

Figure 13: Mounting the outer rotor to the drive side (A5)

Caution



The assembly requires forced guides if there is a risk of contact between the outer rotor and the canister (especially in the case of larger permanent magnetic couplings).

For the further assembly sequence, please refer to section 4.3 ff.

4.2 Permanent magnetic coupling with SSiC plain bearing

- 1 inner rotor
- 2/A2 canister
- 3 outer rotor
- 4 motor hub
- 5 dowel pins
- 6 cap screws
- 7 set screw
- 8 SSiC plain bearing
- 9 dowel pins
- 10 cap screws

(Pos. 4...7 if ordered with motor hub)

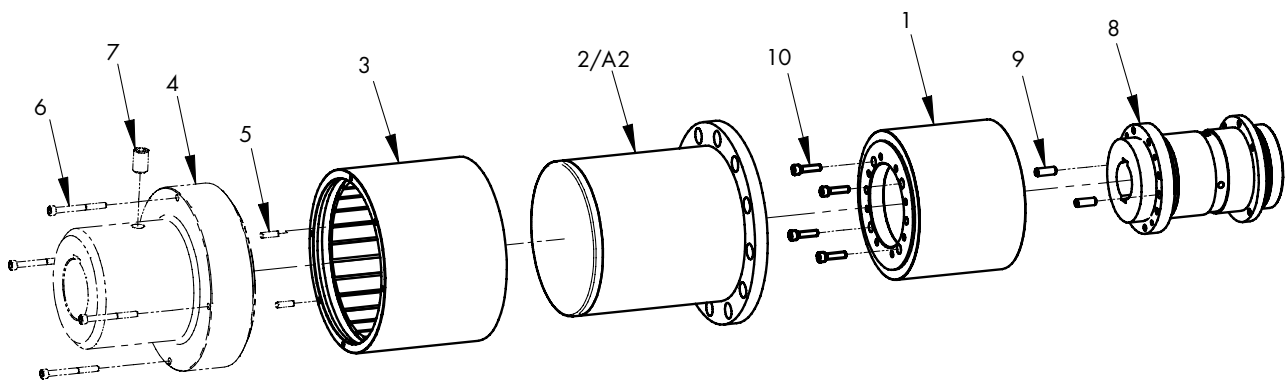
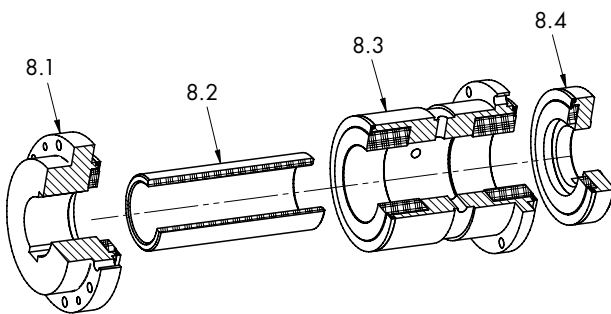

Figure 14: Overview of permanent magnetic coupling with SSiC plain bearing

Position 8 represents the SSiC plain bearing and consists of the following individual parts:



- 8.1 Axial bearing bracket I
- 8.2 Longitudinal bearing
- 8.3 Radial bearing bracket
- 8.4 Axial bearing bracket II

The 4 individual parts of the SSiC plain bearing are supplied in assembled condition. For safe assembly, each individual part must be mounted separately.

Figure 15: Components of the SSiC plain bearing

4.2.1 Pre-assembly of the inner rotor

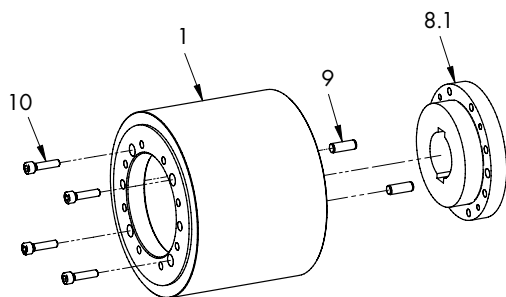

- Insert dowel pins (9) into the fitting holes of the inner rotor (1).
- Centre the axial bearing bracket I (8.1) in the inner rotor (1) via the dowel pins (9).
- Screw the axial bearing bracket I (8.1) and the inner rotor together by means of cup screws (10).

Figure 16: Mounting axial bearing bracket I with inner rotor (A6)

4.2.2 Pre-assembly of the SSiC plain bearing onto the output shaft

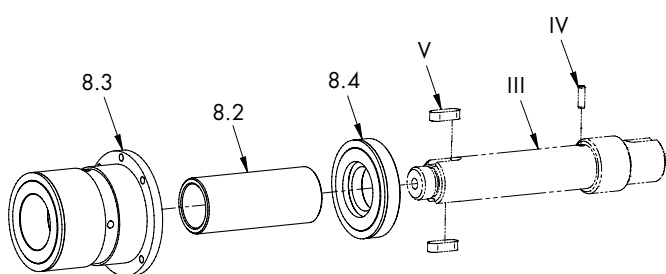

- Insert dowel pin (IV) into the customer's output shaft (III).
- Push axial bearing bracket II (8.4) onto the customer's output shaft (III) and push it into the dowel pin connection until it comes to a stop.
- Push the longitudinal bearing (8.2) and the radial bearing bracket (8.3) onto the customer's output shaft (III).
- Insert parallel keys (V) into the grooves of the customer's output shaft (III).

Figure 17: Mounting the SSiC plain bearing to the output shaft (A7)

4.2.3 Assembly of the SSiC plain bearing with inner rotor and output side

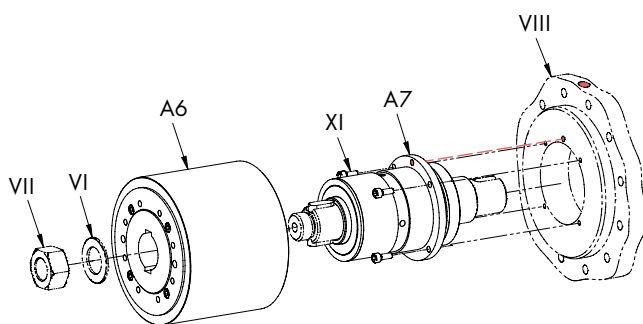

- Centre the pre-assembled SSiC plain bearing with the customer's output shaft (A7) on the customer's flange (VIII) using cap screws (XI) and fasten.
- Slide the pre-assembled inner rotor (A6) onto the keyway connection of the pre-assembled SSiC plain bearing with the customer's output shaft (A7).
- Fix the pre-assembled inner rotor (A6) axially by using a washer (VI) and hexagon nut (VII)/cap screw.

Figure 18: Assembly of the SSiC plain bearing with the inner rotor and the output side (A8)

Caution

Depending on the position of the cooling hole in the flange (VIII), make sure during assembly that the cooling hole is not covered by the radial bearing bracket (8.3).

For the further assembly sequence, see section 4.3.

4.3 Mounting aids/forced guides

For safe installation, the permanent magnetic coupling is brought together with the help of a mounting aid. It must therefore be ensured during installation that the outer rotor and canister do not come into contact. An example of the forced guidance/assembly aid can be seen in Figure 19.

- Screw the assembly aid (e.g.: threaded rods with nuts) into the drive side (A5)
- Bring output side (A4/A8) and drive side (A5) together coaxially using the assembly aid (e.g.: Bring together by adjusting the nuts (XII) on the threaded rods (XI))
- Remove the assembly aid
- Screw the output side (A4/A8) to the drive side (A5).

Other examples of forced guides/assembly aids:

- The studs that are screwed into the output side (A4/A8) run in a fit with the drive side (A5) and center it. In vertical installation, the drive side (A5) is lowered over the studs guided in the fit of the output side (A4/A8) by a lifting means and mounted coaxially.
- The studs that are screwed into the output side (A4/A8) run in a fit of the drive side (A5) and center it. In horizontal installation, further screws in the drive or output side are used to continuously reduce the distance between the components that attract each other.

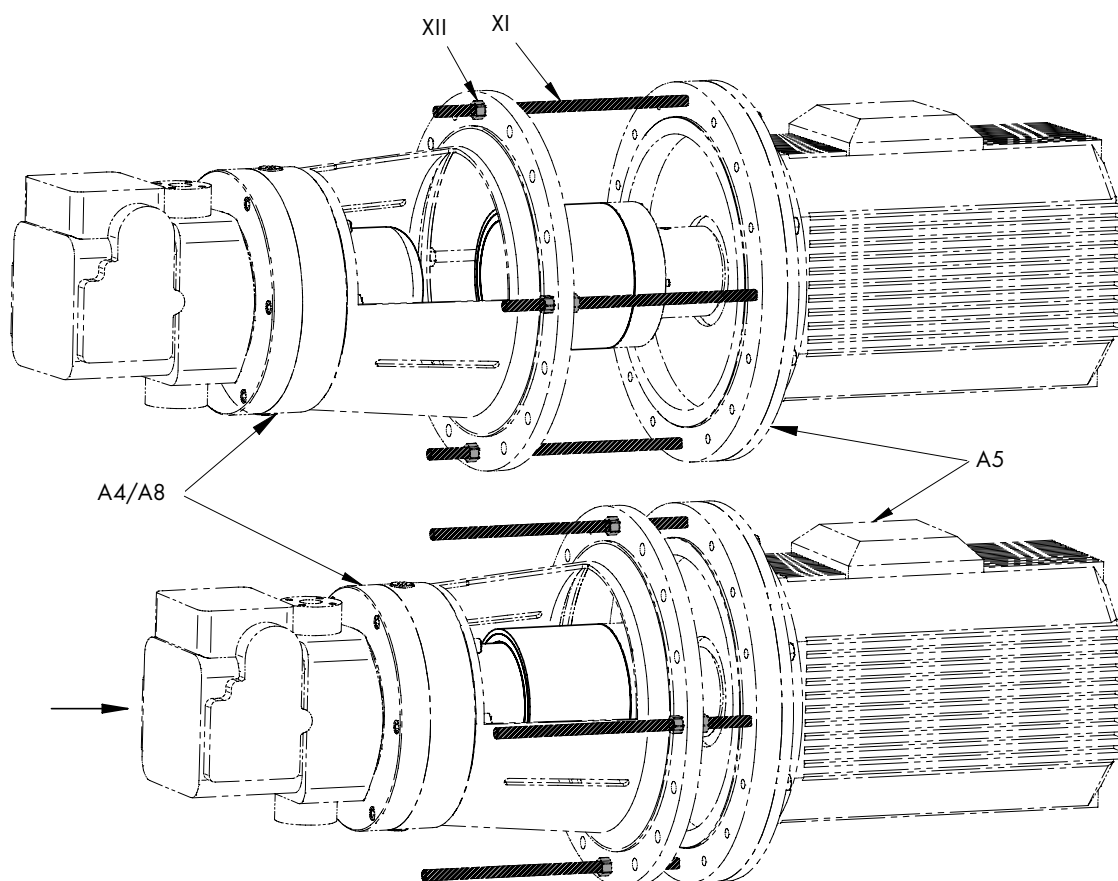

Figure 19: Example of a mounting aid (option and mounting aid not included in the scope of delivery)



When the outer and inner rotors are assembled, mutual attraction forces occur between the rotors. During assembly, the outer and inner rotors can attract each other and cause unintentional collisions and damage.



The mutual attraction of the outer and inner rotor can become a crushing hazard for persons.

4.4 Permissible deviations in assembly

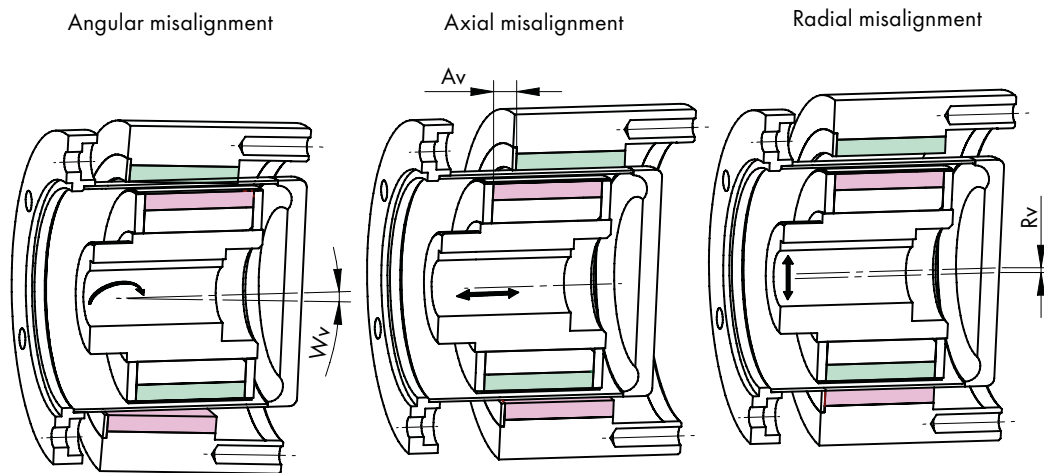

Figure 20: Permissible deviations in assembly

To ensure proper functioning, the following points must be taken into account during assembly:

- For permanent magnetic couplings, the deviation in the radial distance (air gap) between the inner rotor and the canister, as well as between the outer rotor and the canister, must not be more than 30% of the smallest value of the air gap according to the drawing of the permanent magnetic coupling

$$R_{V,max} = 0.3 \cdot \text{air gap}_{min}$$

- The axial displacement from the inner rotor to the outer rotor must not deviate by more than $\pm 2\text{mm}$

$$A_{V,max} = \pm 2 \text{ mm}$$

- The angular displacement from the inner rotor to the outer rotor must not deviate by more than 1° (applies only to DST standard couplings)

$$W_{V,max} = \pm 1^\circ$$

Caution

Before commissioning, the deviations in assembly of the permanent magnetic coupling must be checked. The deviations must be within the permissible deviation range (the deviations can limit each other) and must be ensured by the assembly personnel. The check dimensions on the assembly drawing must be observed for proper operation. Failure to observe the maximum permissible deviations during installation may result in reduced torque transmission or malfunctions (e.g.: sparking, frictional heat).



Exceeding the permissible deviations can mean the loss of explosion protection and become a potential source of ignition.

4.5 Screw tightening torques

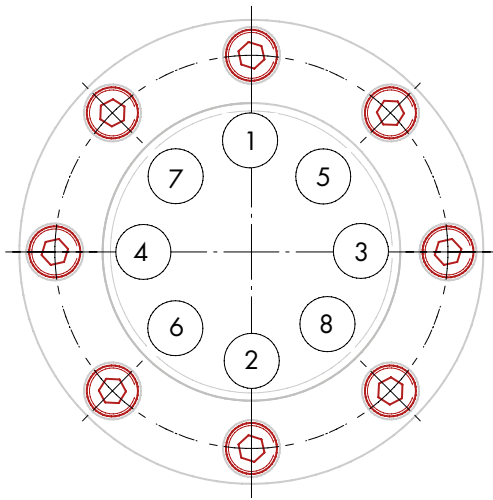

When tightening the screws, the tightening torque specified by DST must be observed. All screws must be tightened crosswise in several cycles (see Figure 21) using a calibrated torque wrench. Increase the tightening torque with each cycle until the maximum value (see Table 3) is reached.

Caution



Depending on the application, especially for explosion prone (Ex) areas, the screws must be secured against self-loosening (e.g. using temperature-resistant screw locking adhesive), unless self-locking screws are used. In the standard delivery condition, the screws are not secured against self-loosening.

Figure 21: Screw tightening sequence

Hexagon head bolts ISO 4017	Property class - 8.8 ¹⁾		
Hexagon socket head cap screws ISO 4762			
Hexagon nuts ISO 4032			
Studs DIN 938	Property class - 8.8 ¹⁾		
Metric ISO threads	Tightening torque (Nm) ²⁾³⁾ VDI 2230		
	Bolt/Screw connection in steel/stainless steel ⁴⁾	Bolt/Screw connection in Aluminium	when using PEEK canister
M5	5.9	-	-
M6	10	-	-
M8	24.5	12	18.5
M10	48	23	36
M12	84	40	-
M16	206	100	-
M20	415	190	-
M24	714	337	-

¹⁾ Other strength classes of the screws can be realized after consultation with DST.

²⁾ The tabulated values do not apply if different values are indicated on the drawings or by other instructions.

³⁾ Tightening torques are based on the assumption that the coefficient of friction is 0.12.

⁴⁾ The tightening torques are valid for canisters made of metal, ceramic and borosilicate with metal flange.

Table 3: Tightening torque for standard fastening screws

4.6 Disassembly

The disassembly procedure is carried out analogously in reverse order to the assembly.



During disassembly, there is a risk of injury due to hazardous and/or hot pumped media! Secure the machine against unintentional start-up.



During disassembly, the outer and inner rotors must be permanently and safely separated (observe section 6.2 Storage).

- The legal regulations must be observed. When draining the pumped medium, protective measures must be taken for persons and the environment.

5. COMMISSIONING/OPERATION

Before commissioning, section 2.1 and 4 must be ensured. Make sure that all associated components (e.g.: speed sensors, temperature sensors, etc.) are properly mounted and functional.

The torque value of the permanent magnetic coupling is always the static torque (breakaway torque). The dynamic torque depends on the dynamics/moment of inertia of the complete system. The user is responsible for the complete system.



The materials of the components must withstand the respective operating conditions against mechanical/thermal/chemical influences or corrosion.

Unauthorized modifications to DST components will invalidate any warranty provided by DST.

5.1 Temperature limits



Exceeding the permissible temperature limits will cause damage to the permanent magnetic coupling and ultimately to the machine!

- Operating temperature for DST standard and high temperature magnets:

Permanent magnetic material	Maximal permissible operating temperature T_{max}	
	DST-standard	high temperature application
NdFeB	max. 150°C	up to max. 230°C
Sm ₂ Co ₁₇	max. 350°C	up to max. 500°C

Table 4: Temperature limits for DST standard and high temperature magnets

- Operating temperatures for DST standard canisters:

Standard-canister		Temperature range ²	
Category	Material ¹	T _{min}	T _{max}
Metal	1.4571 (stainless steel)/ 2.4610 (hastelloy)	-110°C	+450°C
	3.7165 (titanium Gr. 5)	-196°C	+350°C
	Non-Metal		
	Ceramic (Mg-PSZ)	-30°C	+450°C
	Borosilicate	-196°C	+450°C
	CFRP with PTFE inliner	-20°C	+180°C
	PEEK	-196°C	+120°C

¹ Other materials on request
² With increasing temperature, the mechanical strength of the canister and the maximum permissible operating pressure decreases

Table 5: Temperature limits for different canister materials

5.2 Pressure ranges



Exceeding/falling below the permissible pressure range from the data sheet can result in the canister bursting/collapsing. The leakage of the operating media can become a hazard to people and the environment.



The general pressure values are dependent on the size and apply at 20°C. The maximum permissible operating pressure decreases as the temperature rises. The effective operating pressure depends on the design of the canister and can be found in the product data sheet or can be requested from DST.

Canister material	Pressure ranges		Size	
	Min.	Max.	from	to
1.4571 / 2.4610	vacuum	25 bar	27	200
3.7165 (titanium Gr. 5)	vacuum	320 bar	27	200
Ceramic (Mg-PSZ)	vacuum	25 bar	60	200
Borosilicate	ultra high vacuum	16 bar	27	110
CFRP with PTFE inliner	2 bar	63 bar	customized	
PEEK	vacuum	16 bar	75	165

Other pressure ranges and sizes are available on request.

Table 6: Overview of the pressurization of canisters

- For more information on temperature limits in explosion protection environment (ATEX) applications, refer to Section 7.

5.3 Lubrication of the SSiC plain bearings

Lubrication of the SSiC plain bearing is carried out by the operating medium during operation. The bearing must be checked for wear for the following scenarios:

1. After dry running and/or cavitation operation and at a dynamic viscosity of the operating medium < 1 mPas, an immediate check must be carried out.
2. Vibrations, noises and increased current consumption under otherwise constant operating conditions indicate bearing wear (insufficient lubrication). The bearings must be checked immediately.

5.4 Losses during operation

During operation of the permanent magnetic coupling, eddy current losses and/or hydraulic friction losses may occur. The performance of the permanent magnetic coupling may be limited due to the losses and the overall dynamics of the system. The resulting heat at the permanent magnetic coupling as a result of the losses may have to be dissipated.

5.4.1 Eddy current losses

When using a permanent magnetic coupling (especially with metallic canisters), eddy current losses are expected. The value of the losses depends on the size, the material of the magnetic coupling/canister and the operating parameters.

Eddy current losses can be greatly reduced when using a permanent magnetic coupling with non-metallic canisters. CFRP canisters with PTFE inliner have negligible eddy current losses up to a speed of 3000 1/min. Eddy current losses can be kept negligible by using canisters made of ceramic.

5.5 Maintenance

The DST permanent magnetic coupling is basically maintenance-free.

Depending on the operating medium/end application, it may be necessary to perform regular inspections. The inspection/maintenance intervals are determined by the end user.

During each maintenance it is recommended to check the components (esp. outer/inner rotor, canister, bearings, static seals) for signs of wear and the permissible deviations (see section 4.4 Permissible deviations in assembly)

Caution

Dry running causes severe damage to the SSiC plain bearing and can lead to problems and malfunctions on the output side!

The use of SSiC plain bearings in operating media with a dynamic viscosity (μ) of $0.3 \text{ mPas} \leq \mu < 1 \text{ mPas}$ is only permissible after consultation with DST if the axial play and the surface finish are designed and/or adjusted accordingly.



The permanent magnetic coupling must be cooled by a partial flow of the fluid conveyed or by cooling of the outer rotor for the explosion protection area.

5.4.2 Hydraulic friction losses

When operating a permanent magnetic coupling with metallic or non-metallic canister, hydraulic friction losses must be expected. The amount of losses depends on the dynamic viscosity of the operating medium, the speed and the size of magnetic coupling.

Caution



During maintenance and repair work, potential ignition sources (especially hot surfaces, mechanical sparks and electrostatic charges) must be taken into account and avoided by maintenance personnel (e.g.: impact sparks due to abrupt attraction of magnetic components).

5.6 Malfunctions: Causes and elimination

Vibrations, noise and increased current consumption under otherwise constant operating conditions indicate abrasive damage.

Malfunction	Possible causes of malfunctions	Ignition hazards for the Ex-area	Elimination
No sufficient torque or slipping of the permanent magnetic coupling	Operating temperature too high	Ignition hazard due to hot surfaces	<ol style="list-style-type: none"> 1) Set system out of operation 2) Check static torque including losses for operating parameters/drive side 3) Reduce starting torque (dyn. moment of inertia of output side should be lower than permanent magnetic coupling torque) 4) If insufficient torque is available, replace coupling for higher torque if necessary (observe connections, installation space, dynamic behavior and operating parameters)
	Starting torque of the motor too high (starting torque > permanent coupling torque)		<ol style="list-style-type: none"> 1) Set system out of operation 2) Remove blockage 3) Check coupling parts for damage (check inner rotor and canister for traces of friction) 4) Empty and clean the interior of the canister 5) If necessary, plan regular cleaning and/or increase the air gap between the internal rotor and the canister
	Blockage of the output side	<ol style="list-style-type: none"> 1) Set the system out of operation 2) Visually inspect the outer rotor and the canister for signs of friction 3) Replace outer rotor or permanent magnets 4) Check the permanent magnetic coupling torque 	
	Loose magnets in the outer rotor due to assembly error		<ol style="list-style-type: none"> 1) Set the system out of operation 2) Rectify the reason for the alignment error 3) Check for wear and, if necessary, replace the components in the event of damage/grinding marks/contact points 4) Re-align (adjust within permissible deviations) and check permanent magnetic coupling torque
Change in running noise/increased power requirement	Alignment errors (axial displacement, radial displacement and angular displacement)	Ignition hazard due to mechanical sparks and hot surfaces	
	Bearing damage due to abrasion or dry running of the SSiC plain bearings		Not valid for hazardous area*

* If necessary, the approval can be applied.

General prerequisites:

- Complete use of the permanent magnetic coupling and its individual/spare parts (original parts) supplied by DST as well as standard parts suggested by DST.
- No combination of permanent magnetic couplings from DST and other manufacturers with each other
- Compliance with the operating and assembly instructions provided by DST
- Flawless condition of the permanent magnetic coupling (free of damage, no corrosion/transport damage, undamaged fits/surfaces)

Table 7: Causes of malfunctions and their elimination

6. TRANSPORT, STORAGE, RETURN AND DISPOSAL



The outer and inner rotor have a strong magnetic field.

6.1 Transport

Unless otherwise contractually agreed, the permanent magnetic couplings or individual parts are packaged according to the DST packaging standard, depending on size, quantity and type of transport. Customer-specific packaging and packaging for air transport (IATA-packaging regulation 953) are available on request.

For further transport, the outer and inner rotor must be packed separately from each other and from the other components according to the standard of logistics.

6.2 Storage

Caution

The permanent magnetic coupling must be protected against moisture and mechanical damage. The permanent magnetic coupling must not be exposed to frost, direct sunlight or temperatures above +50°C.



The permanent magnetic coupling must be placed at a sufficient distance from magnetic components during storage to avoid abrupt attraction and resulting damage.

Damage may occur due to moisture, dirt or pests. This can lead to corrosion/soiling of the components.

The permanent magnetic coupling should be stored in a dry, protected room with humidity as constant as possible. To protect the product, proper and professional indoor storage is necessary.

6.3 Return



Warning

The permanent magnetic coupling must be properly cleaned by the customer before return to prevent the risk of poisoning/contamination by harmful, explosive and other high-risk pumping media for people and the environment.

If pumped media whose residues with atmospheric humidity could lead to a corrosion damage or ignite on contact with oxygen, the permanent magnetic coupling must also be neutralized and adequately cleaned with anhydrous, inert gas for drying.

The permanent magnetic coupling must always be accompanied by a fully completed declaration of clearance (section 11).

All applied securing and decontamination measures must be specified.

The permanent magnetic coupling must be packed according to the standard of logistics

6.4 Disposal



Warning

There is a danger to personnel and the environment when using pumped media that are hazardous to health and/or hot!

The emptying and disposal of hazardous liquids and the components of the permanent magnetic coupling must be carried out in compliance with the statutory regulations.

- Wear protective clothing and a protective mask
- Collect rinsing liquid and residual liquid and dispose of properly

The materials must be disposed of properly as follows:

- Metal
- Magnetic material (special waste)
- Plastics
- Grease and lubricants
- etc.

7. EXPLOSION PROTECTION

Special conditions apply to the operation of explosion-proof permanent magnetic couplings according to EU Directive 2014/34/EU.

In potentially explosive atmospheres, only permanent magnetic couplings which have a corresponding marking and are designated for this purpose according to the product data sheet may be used. Explosion protection is only guaranteed when used as intended.

Caution

All safety instructions mentioned in this operating manual are also valid for the use of the permanent magnetic coupling in the explosion protection area!

7.1 Labeling

Labeling of the permanent magnetic coupling:

II 2G Ex h IIC T6 .. T1 Gb X
-40 °C ≤ T_E ≤ +350 °C

The marking is the ATEX approval of the DST permanent magnetic coupling (only for the outer/inner rotor and canister) and applies to the sizes DST 27 to 200.

Due to the different coupling designs (canister materials) and their permissible temperature ranges, temperature classes between T6 and T1 result according to Table 8 and 9.

The marking of the permanent magnetic coupling ends with an "X" and indicates special conditions for safe use in the explosion protection area, which are described in section 7 or marked with an Ex-symbol in these operating/assembly instructions.

7.2 Temperature monitoring / limits

The permanent magnetic couplings with metal canisters, CFRP canisters with PTFE inliner and PEEK canisters may only be operated in potentially explosive atmospheres with temperature monitoring which automatically stops the drive when a certain shutdown temperature is reached.

The design of the temperature monitoring system must meet the requirements of Directive 2014/34/EU. For permanent magnetic couplings with ceramic canisters, the requirement for operation with temperature monitoring does not apply.

Caution

Unauthorized modification of DST components voids the warranty obligation of DST. The use of the components in potentially explosive atmospheres is therefore no longer permitted.

All components of the permanent magnetic coupling should be incorporated in the electrical grounding/equipotential bonding.

Labeling of the type examination certificate:

IBExU04ATEXB020 U

A "U" after the type examination certificate indicates that this certificate must not be confused with a certificate for equipment or protective systems. This partial certificate may only be used as a basis for the certification of a device or protective system.

According to ISO 80079-36 (6.2.5, Table 2), Group II equipment are classified in a temperature class depending on the maximum surface temperature as given in Table 8. The maximum surface temperature shall not exceed the temperature class limits according to table 8 or shall not exceed the auto-ignition temperature of the specific operating medium.

Additionally, according to EN 1127-1 (6.4.2) if the operating medium can be heated to the temperature of the surface (losses in the permanent magnetic coupling), the surface temperature shall not exceed 80 % of the minimum ignition temperature of the operating medium measured in °C.

Temperature classes according to ISO 80079-36	Max. surface temperatur in °C
T1	≤ 450*
T2	≤ 300
T3	≤ 200
T4	≤ 135
T5	≤ 100
T6	≤ 85

* The unfavorable temperature limit of the canister material and the permanent magnet material determines the temperature class of the entire permanent magnetic coupling. The operating temperature range of the permanent magnetic coupling is $-40^{\circ}\text{C} \leq T_e \leq +350^{\circ}\text{C}$.

Table 8: Classification of maximum surface temperatures for Group II equipment according to ISO 80079-36 (6.2.5, Table 2)

If the setup permits, it is recommended to mount the temperature sensor (XIII) between the canister flange and the outer rotor as shown in Figure 22. Since heat generation is highest near the rotor, the sensor must be positioned as close as possible to the outer rotor without undercutting the minimum distance of 3 mm. The permanent magnetic couplings are not prepared to house temperature sensors as standard. If required, the design of the permanent coupling must be modified.

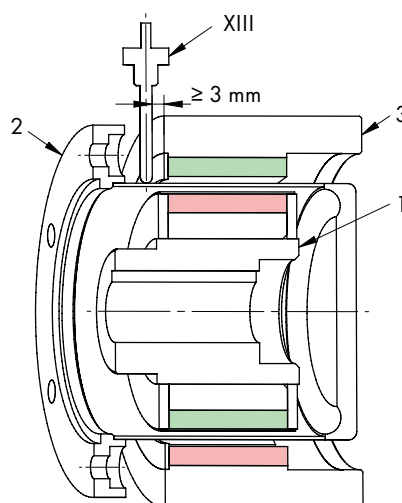

Figure 22: Temperature monitoring example

The maximum surface temperature includes the temperature of the operating medium and the heat generation due to losses. Since the maximum surface temperature depends strongly on the oper-

ating conditions, a permissible temperature class range is defined for the permanent magnetic coupling with corresponding canister material:

Standard canister		Temperature class range
Category	Material ¹⁾	(ISO 80079-36)
Metal	1.4571 (stainless steel)/2.4610 (hastelloy)	T6 .. T1
	3.7165 (titanium Gr. 5)	T6 .. T2
Non-metal	Ceramic (Mg-PSZ)	T6 .. T1
	Borosilicate	not permitted
	CFRP with PTFE inliner	T6 .. T4
	PEEK, 30% carbon-fiber reinforced	T6 .. T5

¹⁾ Materials differing from the standard must be approved for the Ex-area on application.

Table 9: Temperature classes for different canister material in explosive atmospheres

Caution

Under Consideration of the operating temperature and the heat generation due to the losses, the end user must determine the shutdown temperature in such a way that there is

no danger of ignition during normal operation or expected malfunctions.

7.3 Materials in explosive areas

The permanent magnetic couplings may only be used if their materials are so resistant to mechanical and/or chemical influences or corrosion under the respective operating conditions that the explosion protection is not cancelled. The following materials are mainly used:

Permanent magnetic coupling component	Material ¹⁾
Outer rotor	St52-3 / 1.4571
Canister	1.4571 / 2.4610 / 1.4980 / titanium (3.7165) / ceramic (Mg-PSZ) / PEEK, 30% carbon fibre reinforced / CFRP with PTFE-inliner
Inner rotor	encapsulated in 1.4571
¹⁾ For materials other than those listed in this table, please contact DST.	

Table 10: Predominant use of materials in explosive areas

7.4 Protective measures of the ignition sources

Summary of possible ignition sources during normal operation and expected malfunctions with the implemented protective measures:

Ignition hazards			
Ignition source type	Identified ignition hazard	Realized protective measures	Reference
Hot surfaces	slipping of the permanent magnet coupling	temperature monitoring,	5.4
	high losses (eddy current losses, hydraulic friction losses)	cooling by convection, operating/or cooling medium	7.2
	sparking /thermal losses from damaged bearings	regular inspection intervals, temperature monitoring	5.5 7.2
Mechanical sparks	grinding of foreign bodies/components on components rotating relative to each other	definition of permissible deviations in installation, protective cover according to RL 2014/34/EU	4.4 7.4
	vibrations of the rotating components, loose components	notes on screw tightening torques, manufacturer's information on permissible operating parameters	4.5 [1]
Electrostatic charges	-	(canister) materials are electrically conductive/dissipative (<1 GΩ)	[2]
[1] Product data sheet of permanent magnetic coupling			
[2] Type examination certificate and test reports			

Table 11: Ignition sources and their protective measures

On request, the ignition hazard analysis is available.

The user must protect the permanent magnetic couplings with fixed covers in accordance with ATEX Directive 2014/34/EU, in particular against the impact of falling objects (protection against ingress of foreign bodies). The cover must be electrically conductive and be incorporated in the electrical grounding/equipotential

Caution

Permanent magnetic couplings with a SSiC plain bearing and canister made of borosilicate are not suitable for the potentially explosive atmosphere.

The selection of the material for the wetted parts, canister and mostly the inner rotor (rarely outer rotor, if pressure acts from outside on the canister) is mainly determined by the resistance to various media. Thus, in addition to the materials already mentioned, the material 1.4404 is also used.

bonding and have a minimum distance of 5 mm to moving parts. Removal of the cover is only permitted when the machine is at a standstill. The outer rotor must not run in dust piles.

8. GLOSSARY

EU Certificate of Conformity

The certificate of conformity is a written confirmation at the end of a conformity assessment, with which the person responsible (e.g. manufacturer, distributor) for a product, the provision of a service or an organization (e.g. testing laboratory, operator of a quality management system) bindingly declares and confirms that the object (product, service, body, QMS) has the properties specified on the declaration. The specification of the properties is usually done by specifying the standards that the object complies with.

IATA Packing Instructions 953

The International Air Transport Association (IATA) issues a set of regulations for the transport of dangerous goods (Dangerous Goods Regulations; DGR) in aviation based on the requirements of the International Civil Aviation Organization (ICAO).

This instruction applies to UN 2807 (magnetized material) on passenger aircraft and on cargo aircraft only. Magnetized material will only be accepted if:

- (a) Equipment such as magnetrons and light meters are packed so that the polarities of the individual units are opposite to each other;
- (b) permanent magnets are provided with holding bars where possible;
- (c) magnetic field strength at a distance of 4.6 m from any point on the surface of the packaged shipment:
 - (1) does not exceed 0.418 A/m (0.00525 gauss); or
 - (2) produces a magnetic compass deflection of 2 degrees or less.

For the packaging of DST permanent magnetic couplings, c) must be observed

Conversion kit

The DST conversion kit consists of a permanent magnetic coupling with the associated components for centering, bearing, sealing and fastening of the permanent magnetic coupling to a drive and output. The drive (e.g. motor) and output (e.g. pump) are centered and mounted on the conversion kit by the end user. The conversion kit provides an interchangeable connection between the drive side and output side, which is used to replace the coupling type of the system with the permanent magnetic coupling by the customer. The drive (e.g.: motor) and output (e.g.: pump) are centred and mounted on the conversion kit by the end user.

Clearance certificate

A clearance certificate is a declaration by the user that the coupling or conversion kit has been properly drained and cleaned so that there is no risk of subsequent contact of fluid wetted components with people or the environment.

Mounting aids/forced guideways

A forced guide/assembly aid is a guide which prevents unintentional contact in the axial and radial direction during assembly of the individual coupling parts.

9. CERTIFICATE OF CONFORMITY

	EU-Certificate of conformity (ATEX)	FM-D-51 Page 1 of 2
EU Certificate of Conformity in reference to guidelines 2014/34/EU (ATEX)		
Manufacturer	DST Dauermagnet-SystemTechnik GmbH Hönnestraße 45 D-58809 Neuenrade	
Product description	Permanent magnetic couplings Type DST 27 to 200	
This certificate is issued under the sole responsibility of the manufacturer.		
The permanent magnet couplings of the types DST 27 to DST 200 are intended for installation in machines such as pumps, agitators, etc.		
The component permanent magnet couplings essentially consist of the components:		
<ol style="list-style-type: none"> 1. outer rotor 2. canister 3. inner rotor 		
The safety-relevant instructions and the conditions for the installation of this component in equipments and protective systems are specified in the operating instructions and are to be adhered to, to ensure that the essential health and safety requirements applicable to assembled equipments and protective systems are met in accordance with Annex II to Directive 2014/34/EU.		
DST Dauermagnet-SystemTechnik GmbH confirms that the above-mentioned products meet the basic safety and health requirements with regard to the construction of products used in potentially explosive atmospheres, as specified in Annex II of Directive 2014/34/EU of the European Parliament and Parliament and of the Council of 26.02.2014.		
The marking of the component permanent magnetic couplings has according to the type examination certificate IBEx-U04ATEXB020 U, issue 3 the following information :		
II 2G Ex h IIC T6 .. T1 Gb X -40 °C ≤ T_e ≤ +350 °C		
The following standards have been applied for the conformity of the above mentioned products with the provisions of this EU Directive.		
DIN EN ISO 80079-36:2016-12 DIN EN ISO 80079-37:2016-12		
The certification number and the marking of the products end with an „X“ and indicate special conditions for safe use in the explosion protection area, which are marked in the operating and assembly instructions.		
FM-D-51	DST Dauermagnet-SystemTechnik GmbH, Hönnestrasse 45, 58809 Neuenrade	Last revised: 12 from 30.06.2022

Express reference is made to the following essential information:

As the permanent magnetic coupling is intended as a component for installation in equipment (machines), the manufacturer of the machine must either pass on the operating and assembly instructions for the permanent magnetic couplings to the operator or he must include the information in accordance with the safety requirements to be observed by the operator in the operating instructions to be drawn up for the equipment (machinery) as a whole.

The permanent magnetic couplings may only be used if their materials are resistant to mechanical and/or chemical influences or corrosion under the respective operating conditions in such a way that the explosion protection is not nullified.

The permanent magnetic couplings with metallic canisters, canisters made of CFRP with PTFE-L and PEEK canisters may only be operated in potentially explosive atmospheres with temperature monitoring, which automatically shuts down the drive when a certain switch-off temperature is reached. **However, for the permanent magnetic couplings with canisters made of ceramics, the requirement for operation with temperature monitoring does not apply.**

The design of the temperature monitoring must comply with the requirements of RL 2014/34/EU. Information for the automatic shutdown of the drive by temperature monitoring system and temperature limits can be found in the operating and installation instructions.

The permanent magnetic coupling must be cooled by a partial flow of the fluid conveyed or by an outer ring cooling.

When assembling screw connections, only screws specified by the manufacturer may be used. When tightening the screws, the torque specified by the manufacturer must be observed. The screws must be secured against self-loosening unless self-locking screws are used.

In the case of permanent magnetic couplings, the radial distance (air gap) between the inner rotor and the canister, as well as between the outer rotor and the canister, as shown in the drawing of the permanent magnetic coupling, must not be more than 30% less than the smallest of the air gap.

The permanent magnetic couplings must be provided by the user with fixed covers which protect the permanent magnetic couplings from the point of view of explosion protection, in particular against the impact of falling objects. The cover must be electrically conductive and included in the equipotential bonding and must have a minimum distance of 5 mm from moving parts. The cover may only be removed when the unit is at a standstill.

It is confirmed that the documentation according to Annex VIII of Directive 2014/34/EU for the above mentioned non-electrical component in accordance with the provisions of Directive 2014/34/EU, Article 13 (1) b) ii), are deposited at the notified body IBExU (EU Identification No. 0637) under No.: IB-22-2-0020, IB-21-2-0097, IB-20-2-0162, IB-18-2-0146, IB-16-4-006, IB-04-4-033 and IB-04-4-013.

Neuenrade, 30.06.22



i.V. Neel Sheth, Head of Technology



Declaration
according to IATA Packing Instruction 953
Translation

Declaration in accordance with
IATA Packing Instruction 953 (packing/inspection of the packaging of magnetic materials)

In accordance with the IATA Packing Instruction 953, the manufacturer

DST Dauermagnet-SystemTechnik GmbH
Hönnestr. 45
58809 Neuenrade

hereby declares that the packaging of the product D037UM001 with the rotors contained therein complies with IATA packing instruction 953, c) and is therefore approved for airfreight shipment.

IATA Packing Instruction 953, c) requires that the magnetic field strength at a distance of 4.6 m from any point on the surface of the packed consignment:

- does not exceed 0.418 A/m (0.00525 Gauss), or
- produces a deflection of the magnetic compass of 2 degrees or less

Neuenrade, 30.06.2022

.....
i. V. Neel Sheth
Head of Technology



**SAFETY DECLARATION FOR RETURN DELIVERIES
(CERTIFICATE OF NON-OBJECTION)**

Last revised: 08/2022

Please reply to info@mag-couplings.com

Permanent magnetic couplings, for which this certificate of conformity has not been completed and signed, can not be inspected or repaired for safety reasons and will be returned unchecked at your expense. This also applies to the exclusive return of canisters, external rotors and internal rotors.

Article number		DST drawing no.	
Quantity		DST reference no.	
Reason for return			

The permanent magnetic coupling (or only the canister, external rotor and internal rotor) was used in health/environmentally hazardous media. No Yes

The permanent magnetic coupling (or only the canister, external rotor and internal rotor) is free from residuals. No Yes

Special safety measures or treatment is necessary or expected. No Yes

The permanent magnetic coupling (or only the canister, external rotor and internal rotor) including accessories was last used with the following media:

	If yes, which		
Solvents	<input type="radio"/> No	<input type="radio"/> Yes*	
Toxic liquids	<input type="radio"/> No	<input type="radio"/> Yes*	
Biologically active liquids	<input type="radio"/> No	<input type="radio"/> Yes*	
Radioactive liquids	<input type="radio"/> No	<input type="radio"/> Yes*	
Corrosive liquids	<input type="radio"/> No	<input type="radio"/> Yes*	
Alkali	<input type="radio"/> No	<input type="radio"/> Yes*	
Explosive liquids	<input type="radio"/> No	<input type="radio"/> Yes*	
Other media	<input type="radio"/> No	<input type="radio"/> Yes*	

* Please add the safety data sheet for the medium in the appendix.



SAFETY DECLARATION FOR RETURN DELIVERIES (CERTIFICATE OF NON-OBJECTION)

Please reply to info@mag-couplings.com

The undersigned assures that the above information is correct and complete and the shipping is carried out according to legal regulations. The undersigned is liable for all damages which arise as a result of the non-marked decontamination of the returned magnetic coupling (or only the canister, external rotor and internal rotor).

DST expressly points out that repairs and verification work is carried out by trusting the correctness of the completion of this safety declaration (certificate of non-objection). Should physical injuries, death or even damage to property occur, claims for damages will be asserted.

Company	
Street / Building no.	
Postcode / Town	
Phone	
Fax	
Email	

Contact

(in capitals)

Date

Signature

(company stamp)

Enclosed



DST Dauermagnet-SystemTechnik GmbH
Hönnestraße 45
58809 Neuenrade / Germany

Phone +49 (0) 23 94 / 616-80
info@mag-couplings.com
www.mag-couplings.com

A company of
e.holding
FLUID TECHNOLOGY GROUP