

# Operating and maintenance instructions



## TABLE OF CONTENTS

	<b>Page</b>
1. Important information and legal notices . . . . .	3
2. General information . . . . .	4
2.1 Details of the pump type . . . . .	4
2.2 Technical data sheet. . . . .	4
2.3 Permissible use. . . . .	4
3. Safety and warning signs . . . . .	5
4. General safety instructions. . . . .	6
4.1 Safety instructions for the user / operator . . . . .	6
4.2 Safety instructions for maintenance / inspection and assembly work . . . . .	7
4.3 Use in areas at risk of explosion (in preparation) . . . . .	7
4.4 Non-permitted forms of operation . . . . .	7
5. Structural design . . . . .	8
5.1 Pump housing . . . . .	8
5.2 Rotor-stator set. . . . .	8
5.3 Shaft, bearing and lubrication . . . . .	8
6. Commissioning – Preparatory work. . . . .	8
7. Commissioning – General . . . . .	9
7.1 Installation position . . . . .	9
7.2 Direction of rotation . . . . .	9
7.3 Venting . . . . .	10
7.4 Connections . . . . .	11
7.5 Drive for ViSCO.mini® (optional) . . . . .	11
7.5.1 Connection assignments for ViSCO.mini® . . . . .	11
7.6 Suction conditions for progressive cavity pumps. . . . .	12
7.7 Speed recommendation / viscosity ranges . . . . .	12
7.8 Medium (recommendation of max. speed). . . . .	12
7.9 Temperature . . . . .	12
8. Storage, return and disposal . . . . .	13
9. Maintenance, service life and warranty . . . . .	14
10. Dismantling and reassembly . . . . .	14
10.1 Basic regulations. . . . .	14
10.1.1 Dismantling the pump . . . . .	14
10.1.2 Assembling the pump . . . . .	14
10.2 Spare parts. . . . .	15
10.3 Related documents. . . . .	16
11. Model code . . . . .	17
12. Certificate of non-objection . . . . .	18

## 1. IMPORTANT INFORMATION AND LEGAL NOTICES

**Dear customer, dear user,**

These operating instructions for the "ViSCO.pump<sup>®</sup>" progressive cavity pumps from Beinlich Pumpen GmbH (Beinlich) contain information required to properly install and commission the pump for its intended purpose.

Any installation, commissioning, operation, maintenance and testing may only be carried out by trained and authorized personnel. The operating instructions must be read carefully and followed in detail to ensure trouble-free, proper and safe operation of the pump. In particular, the safety instructions must be observed.

These operating instructions must be kept in a place where they can be viewed by authorised personnel at all times. The contents of the operating instructions must not be removed at any time. Missing operating instructions or missing pages must be replaced immediately if lost. The operating instructions can be requested from Beinlich or downloaded from our website [www.beinlich-pumps.com](http://www.beinlich-pumps.com) at any time. The operating instructions must be passed on to any subsequent user of the pump.

These operating instructions are not subject to any modification service by Beinlich. Beinlich reserves the right to make technical changes at any time without notice.

Beinlich makes no warranties, express or implied, with respect to commercial qualities and suitability for a particular purpose.

Beinlich accepts no liability for damage and malfunctions resulting from operating errors, failure to observe these operating instructions, improper installation, commissioning or maintenance as well as improper use of the pump.

Opening the pump is generally not permitted. If the pump is opened or modified without authorization, or after a single incorrect connection, Beinlich's warranty and product liability will expire.

The publication of these operating and maintenance instructions renders all information from previous publications invalid. Beinlich reserves the right to make modifications and differences. Beinlich accepts no liability for possible printing errors. Reproduction, even in excerpt form, is permitted only following written consent from Beinlich. Beinlich reserves the right to make technical modifications at any time. Last updated: 05/2023

## 2. GENERAL INFORMATION

These operating instructions form part of the supplied package and must be read before you start using the pump. The instructions in these operating instructions must be followed without exception. Keep these operating instructions in the vicinity of the pump.

### NOTE

No liability will be accepted for any damage or malfunctions arising from failure to comply with these operating instructions. Beinlich Pumpen GmbH reserves the right in the interests of further development to make modifications to individual components or assemblies that are considered to be useful for improving the product while at the same time preserving its key characteristics.

### 2.1 Details of the pump type

The full type designation can be found in the technical data sheet or order confirmation. The serial number is comprised of the order number and a sequential serial

number (e.g. 15/0000-00). It is affixed to the type plate or directly to the pump.

### 2.2 Technical data sheet

The technical data sheet forms part of our order confirmation and contains all of the key technical details that have been agreed between the buyer and the manufacturer.

### 2.3 Permissible use

The pump/pump assembly is only designed for the applications listed in the technical data sheet included with our order confirmation. We recommend checking the material compatibility with the medium. Operating conditions at variance to the ones listed will require new contractual agreements. If the pump/pump assembly

is used in areas at risk of explosion, the addendum to the general operating and maintenance instructions for Beinlich progressive cavity pumps and assemblies for **use in areas at risk of explosion\*** must be observed.

\*In preparation

### 3. SAFETY AND WARNING SIGNS

You must comply with all safety warnings in the operating instructions that are identified as followed:



Warning of mechanical hazard



Read the operating instructions /  
comply with regulations



Warning of hot surface



Enable



Warning of hazardous electric voltage



Secure



Important information for safe and  
fault-free operation



Information, tips

## 4. GENERAL SAFETY INSTRUCTIONS

Every delivery must be checked for any damage sustained during transport immediately after it is received. Commissioning may need to be cancelled. The customer is responsible for the correct set-up of the pump.

Confirmed properties of the pump require compliance with the information in these operating instructions. Ensure that you never use damaged products.

Read the operating instructions carefully before starting any set-up, assembly or maintenance work. Assembly, connection, commissioning and maintenance or repair work must only be carried out by suitably qualified professionals taking account of

- These instructions;
- All other project management documentation, commissioning instructions and circuit diagrams pertaining to the drive;
- National and regional regulations currently in force governing safety and accident prevention.



**Assembly and maintenance work must only be carried out with the drive stationary!  
The unit must be isolated and secured to prevent accidental start-up.**

### 4.1 Safety instructions for the user/operator



**If hot or cold machine parts present a hazard, these parts must be secured against being touched during installation.**



**Contact protection for moving parts, such as the coupling, must not be removed when the machine is in operation.**



**Leakage (e.g. the shaft seal) of hazardous materials (e.g. explosive, toxic, hot) must be dealt with and disposed of so that neither people nor the environment are endangered. Legal obligations are to be complied with.**



**Hazards caused by electrical energy must be eliminated in all instances. (For details of these, see the regulations provided by the VDE, for example, and the energy supply companies). Electrical connections must be installed by trained personnel.**



**Opening of the pump during the warranty period is only permitted following consultation with and approval from Beinlich Pumpen GmbH!**

## 4.2 Safety instructions for maintenance / inspection and assembly work

The operator must ensure that all maintenance, inspection and assembly work is carried out by authorised and qualified professionals who are appropriately skilled following the in-depth study of the operating instructions.

**Work on the pump must only be carried out when it is stationary.**

The procedures for stopping the machine described in the operating instructions must be followed to the letter. Pumps and pump assemblies transporting media that are hazardous to health must be decontaminated. Immediately after work is completed, all safety and security devices must be re-attached and re-enabled. Before recommissioning, the points listed under the Commissioning section must be noted.

## 4.3 Use in areas at risk of explosion (in preparation)

## 4.4 Non-permitted forms of operation

The operational safety of the supplied machine is only guaranteed if it is used correctly in accordance with Section 1– General information of these operating in-

structions. The limit values specified in the data sheet must under no circumstances be fallen short of or exceeded.

## 5. STRUCTURAL DESIGN

### 5.1 Pump housing

The pump is composed of a pump housing, gasket bearing package, rotor-stator set and the optional drive unit. The suction connection is designed as a BSP inter-

nal thread and the pressure connection as a Luer internal thread or BSP external thread.

### 5.2 Rotor-stator set

The rotor is made from stainless steel, and the geometry of the rotor and stator are custom-matched. These two components form the pump's actual pumping unit.

### 5.3 Shaft, bearing and lubrication

The drive shaft is positioned in bearings which have permanent lubrication.



**The pump must always be supplied with liquid. It must never run dry!**



**The pump must not be operated with water.**

## 6. COMMISSIONING – PREPARATORY WORK

The pump may only be commissioned if

- The information in the technical data in the order confirmation matches the conditions of use.
- There is no obvious damage, e.g. caused by storage or transport.
- Sealing caps and cover hoods are undamaged.
- There are no visible leaks or oil loss.
- There is no corrosion or any other signs of incorrect storage or storage in a damp environment.
- All of the packaging material has been removed.



## 7. COMMISSIONING - GENERAL

### 7.1 Installation position

Any

### 7.2 Direction of rotation

Default direction of rotation to the left (CCW)

**Metering  
CCW**

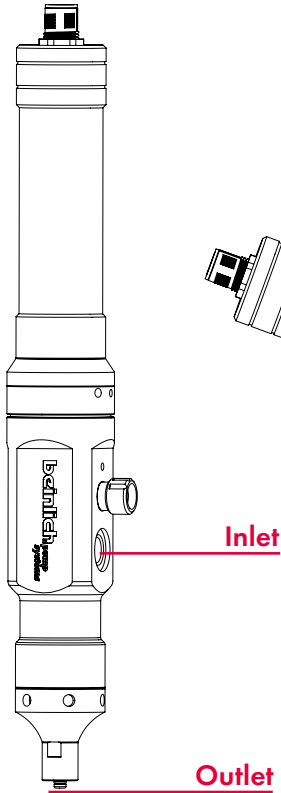

**Pumping  
CCW**

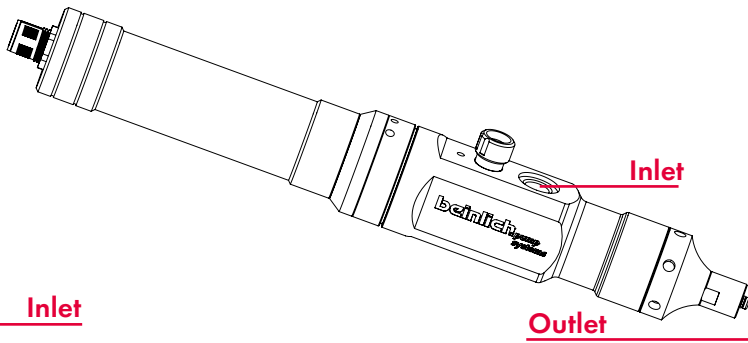

**Draining  
CW**

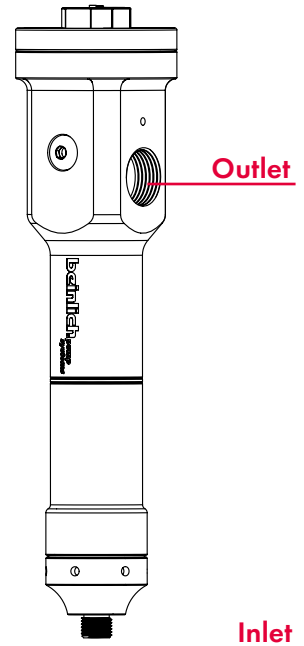
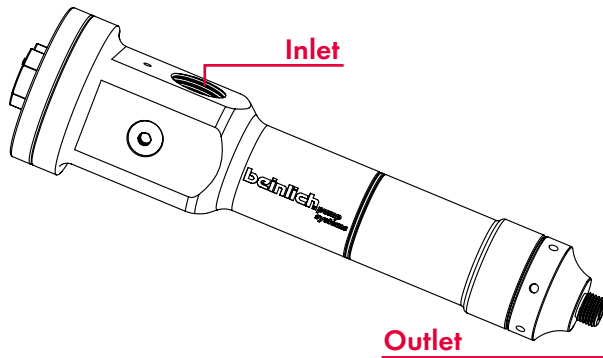
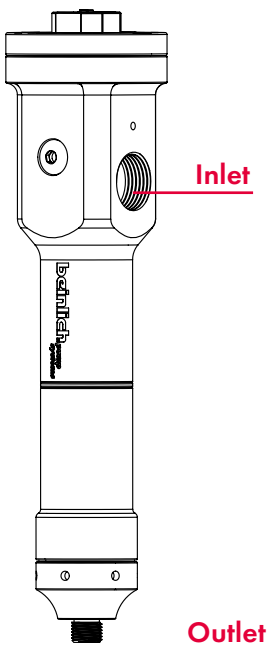
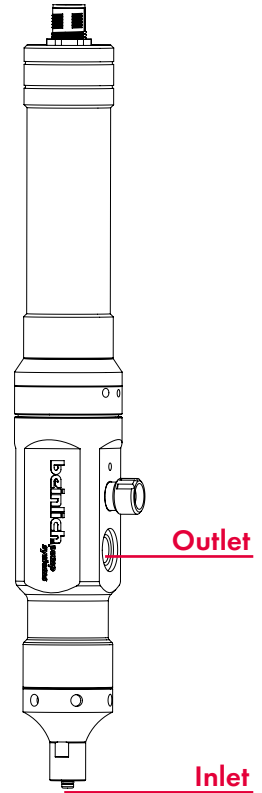

### 7.3 Venting

To operate the pump without malfunctions, it must be ensured that there is no air in the pump and that the pump is completely filled with medium.

There are 2 options for venting the pump.

Option 1 allows the pump to be filled both with the cartridge open and under pressure or with a hose supply.

Option 2, on the other hand, is only suitable for closed cartridges or direct connections.



**Option 1: Danger from spraying medium.**  
 Also note the medium's safety instructions/information

**Option 1:**

- Move the pump into position (Fig.1) and open the cartridge or apply pressure to the container / supply line.
- Loosen the venting screw (item 1) a few millimetres so that air can escape.
- Wait until the medium exits with no air in it.
- Once the medium is exiting with no air in it, stop the pressurised supply of medium.
- Remove any medium that has overflowed and tighten the venting screw.

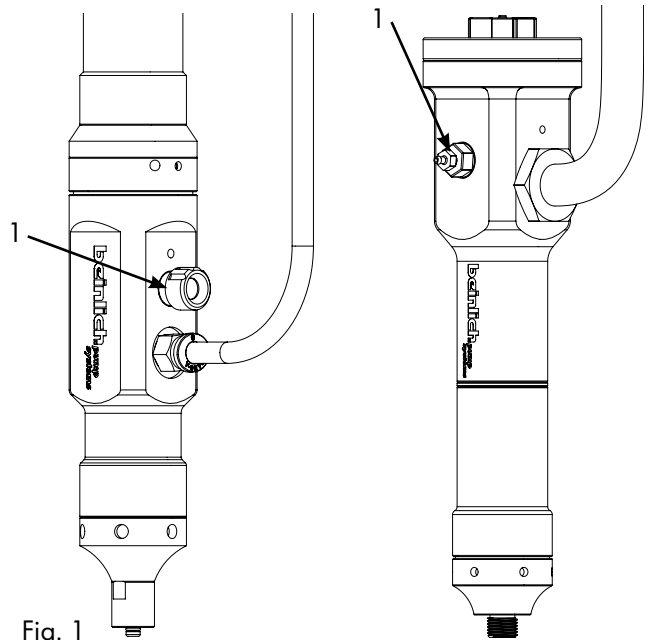

Fig. 1

**Option 2:**

- Set up the pump as shown in Fig. 2.
- Start the pump and pump medium until it exits the outlet without air in it (item 2).

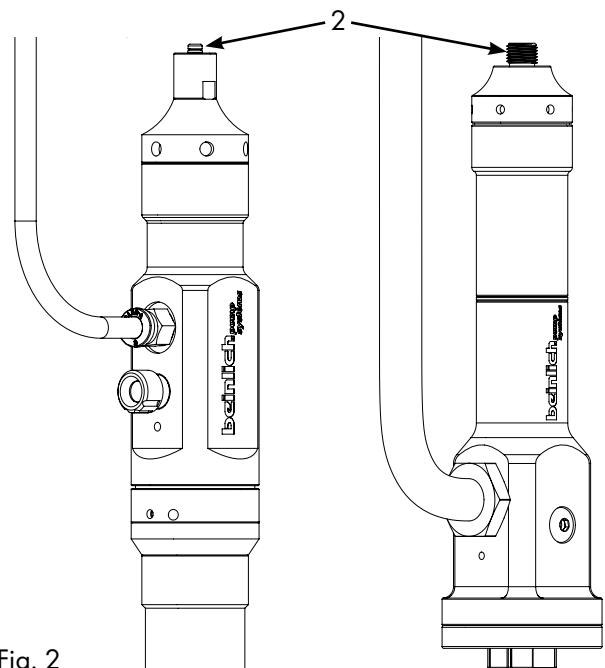

Fig. 2



To avoid contaminating the product, the medium can be evacuated through a hose, for example, at the outlet.

### 7.4 Connections

Default direction of rotation (Left)  
 Supply G 1/8 or G 3/4  
 Outlet Luer adapter or G 1/4



**Due to the risk of contamination, sealants such as hemp or putty are not permitted!**

### 7.5 Drive for ViSCO.mini® (optional)

The drive is effected using a 24 V DC motor with attached planetary gear.

#### 7.5.1 Connection assignments for ViSCOmini®

For Phoenix contact plug – Plug side view

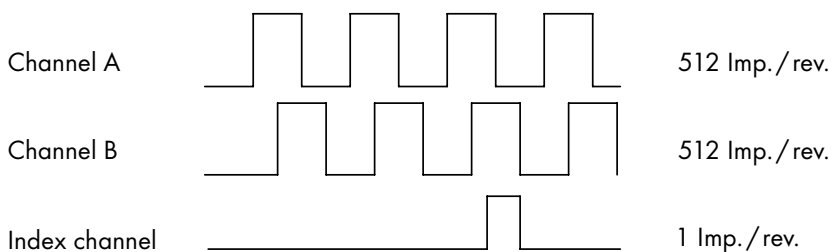
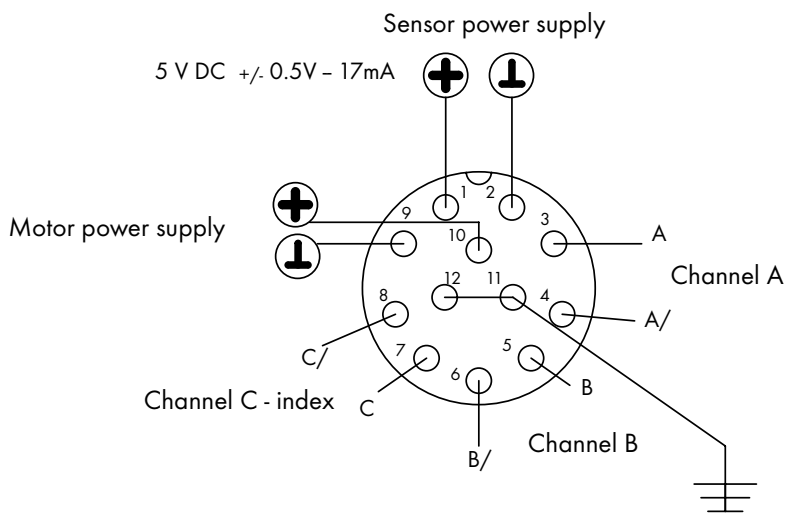

## 7.6 Suction conditions for progressive cavity pumps

The pump is self-priming when certain conditions are met. However with higher viscosity media, the medium must be introduced first (pre-pressure).

The values stated in the technical data sheet for the pre-pressure must not be exceeded. These values may change, depending on the speed and viscosity. The recommendations set out under point 7.8 serve as guideline values for this.

## 7.7 Speed recommendation / viscosity ranges

These recommendations are only guideline values and depend greatly on the application and in situ conditions. The max. permitted speed is crucial for the service life

or wear of the pump. The inlet pressure must be selected within the permissible limits so that continuous filling of the pump is guaranteed.

## 7.8 Medium (recommendation of max. speed)

Viscosity	Max. speed
1 mPa·s – 800 mPa·s	to 100 %
800 mPa·s – 10,000 mPa·s	max. 90 %
10,000 mPa·s – 25,000 mPa·s	max. 70 %
25,000 mPa·s – 50,000 mPa·s	max. 50 %
50,000 mPa·s – 150,000 mPa·s	max. 25 %

Data valid for media without fillers

## 7.9 Temperature

The minimum and maximum temperature depends on the sealing material. Please note that there is a possible change in the medium's viscosity when the temperature changes.

Also take into account the technical data sheet.

## 8. STORAGE, RETURN AND DISPOSAL

### Storage

All Beinlich pumps are supplied with sealing plugs and in suitable packaging for all destinations and modes of transport to ensure optimum protection. The pumps should always be stored in their original packaging. The units must not be exposed to temperatures below  $-20^{\circ}\text{C}$  or above  $+60^{\circ}\text{C}$  and must be protected from moisture and its effects.

When storing the pumps, the following points must be noted:

- Drive units should generally be stored in enclosed rooms.
- Ambient temperature max.  $25^{\circ}\text{C}/77^{\circ}\text{F}$ ; relative humidity max. 80%.
- The stator should be removed from the rotor for storage.
- The progressive cavity pump units must be protected against sunlight and UV light.
- No aggressive or corrosive materials or agents must be stored nearby.
- The units must be protected against mechanical strain and the impact of external forces.

### Return

1. Only cleaned, medium-free pumps can be accepted by Beinlich Pumpen for maintenance or repair. The pump must therefore be properly cleaned by the customer before being returned to prevent the risk of poisoning/contamination by harmful, explosive and other high-risk pumped media for humans and the environment.
2. If media have been conveyed whose residues with atmospheric humidity lead to corrosion damage or ignite on contact with oxygen, the pump must be additionally neutralised and thoroughly cleaned with anhydrous, inert gas to dry.
3. The return of the pump must always be accompanied by a fully completed declaration of non-objection (see section 12, page 18). All applied safety and decontamination measures must be indicated. Pumps for which this safety certificate has not been completed and signed cannot be inspected or repaired for safety

reasons and will be returned uninspected at your expense. The declaration of no objection can be requested from Beinlich Pumpen or downloaded from our website.

4. When returning the pump, it must be packed in accordance with the applicable logistics standards and sealed with sealing plugs.

### Disposal

Beinlich actively promotes environmental awareness and has an operational management system that meets the requirements of ISO 9001:2015. The impact on the environment and people should be minimised during the production, storage, transport, use and disposal of our products and solutions.

- Collect rinsing liquid as well as residual liquid and dispose of it in accordance with the statutory provisions and regulations.
- Wear protective clothing and protective mask/+ goggles if necessary.

Materials must be disposed of properly as follows:

- Metal
- Plastics
- Grease and lubricants
- Electronic components
- etc.

When disposing of the materials, ensure that the waste-relevant rules and regulations of the respective country of destination are observed!

## 9. MAINTENANCE, SERVICE LIFE AND WARRANTY

Beinlich progressive cavity pumps are largely maintenance-free. Gaskets and bearings, as well as the stator and rotor, are subject to wear and must be replaced in certain circumstances at regular intervals. Regular review of the performance data is recommended. Where there is maintenance work being carried out anywhere else on the system, the following points must be considered:

- Check all fastening screws and connections to ensure they are securely tightened and re-tighten if necessary.
- Check the coupling (elastomer) for wear.
- Check the tightness of the pump, especially the shaft seals.

Depending on the operating conditions, the service life and therefore the specific properties of the pumps are limited by wear, corrosion, deposits or ageing. The operator is responsible for regular inspection, maintenance and recalibration. Any observation of a malfunction or damage prohibits further use. On request, we can provide you with a loan unit for the duration of the overhaul. We recommend an annual check and recalibration. Under normal operating conditions, the service life is 10,000 hours. The warranty period is 12 months.

## 10. DISMANTLING AND REASSEMBLY

### 10.1 Basic regulations



**Before starting to dismantle the unit, it must be secured so that it cannot be switched back on. The shut-off devices in the supply line must be closed. The pump must be brought up to ambient temperature.**

#### 10.1.1 Dismantling the pump

Please use the corresponding sectional drawing or installation instructions to help you. Note the position of the parts respective to each other. We recommend marking

the position of the pump parts and numbering them consecutively.



**All dismantling work must be carried out with care. Due to the risk of breakage, do not use force. (Warranty)**

#### 10.1.2 Assembling the pump

Assembly must be carried out with observation of the rules applicable to mechanical engineering. O-rings must be checked for damage and replaced with new ones if necessary. PTFE gaskets must be replaced. All sealant residue must be completely removed.

## 10.2 Spare parts

Please include the following information in spare parts orders:

- Order no.
- Article no. of the pump
- Part no. as per parts list
- Quantity

We only offer a warranty for original spare parts we have supplied. A stock of the most important replacement and wear parts at the pump location is a vital pre-requisite for ensuring the pump is ready for operation at all times. Alternatively, we recommend keeping a spare pump in stock and sending the dismantled pump to our factory for repair if required. Our parts list with sectional drawings diagrams can be used for ordering spare parts. We ex-

pressly point out that replacement parts and accessories that we have not supplied will also not have been checked and approved by us. In certain circumstances the installation and/or use of such products can therefore have a negative impact on the pump's properties by virtue of its design and therefore impair active and/or passive safety.

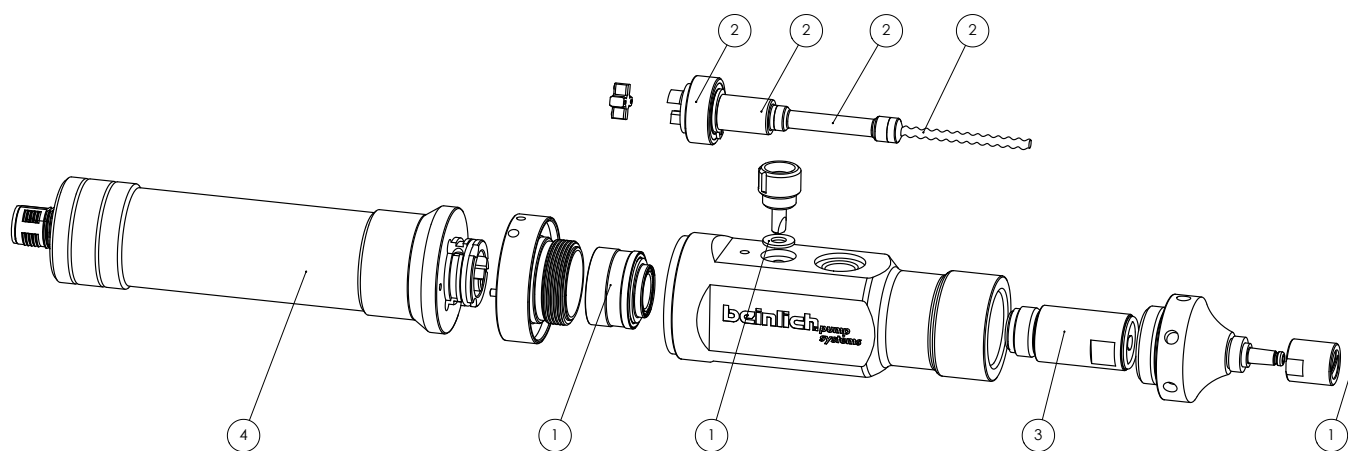

Spare part	Pump							
	0,01		0,05		0,15		0,30	
	FKM	FFKM	FKM	FFKM	FKM	FFKM	FKM	FFKM
Seal kit ①	1K	EDIP1000002	EDIP1000002		EDIP1000002		EDIP1000002	
	2K	EDIP1000003	EDIP1000003		EDIP1000003		EDIP1000003	
Rotor unit ②	EROE0010001		EROE0050001		EROE0150000		EROE0300002	
Stator ③	ESTA0010001	ESTA0010002	ESTA0050003	ESTA0050002	ESTA0150003	ESTA0150002	ESTA0300003	ESTA0300004
Motor assembly ④	EAEH0010009							

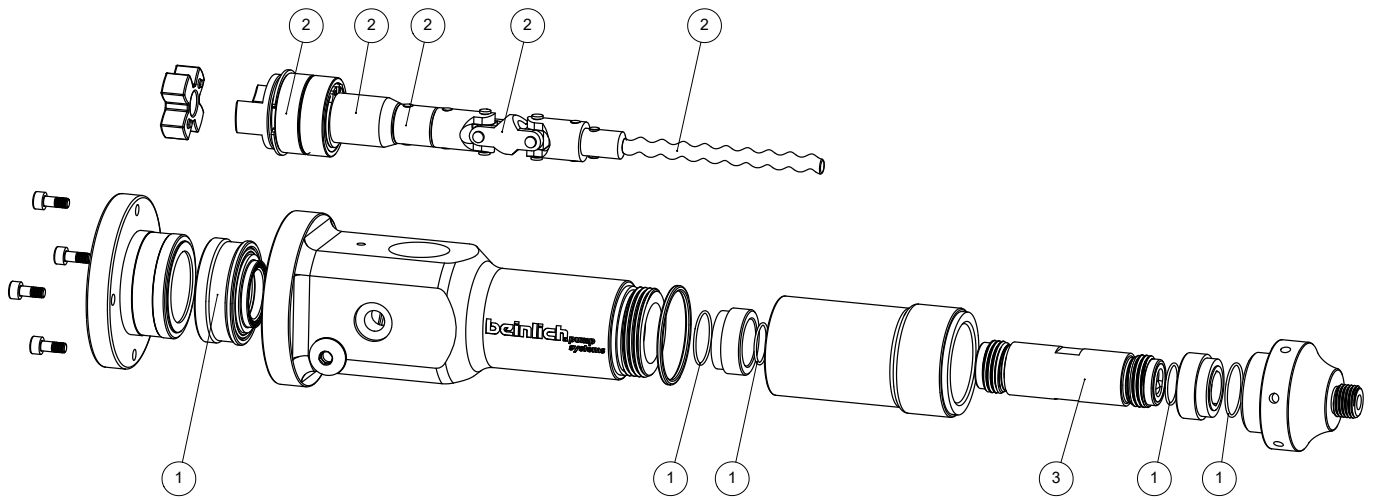

Spare part		Pump							
		0,30		1,00		2,00		4,00	
		FKM	FFKM	FKM	FFKM	FKM	FFKM	FKM	FFKM
Seal kit ①	1K	EDIP0520008		EDIP0520008		EDIP0520014		EDIP0520012	
	2K	EDIP0520016		EDIP0520016		EDIP0520015		EDIP0520013	
Rotor unit ②	FW	EROE0610005		EROE0610006		EROE0610007			
	KG	EROE0300001		EROE1000001		EROE2000001		EROE4000001	
Stator ③		ESTA4040001	ESTA4040003	ESTA3060001	ESTA3060003	ESTA3080001		ESTA3100001	

### 10.3 Related documents

The related documents can be found in the technical data sheet or order confirmation.



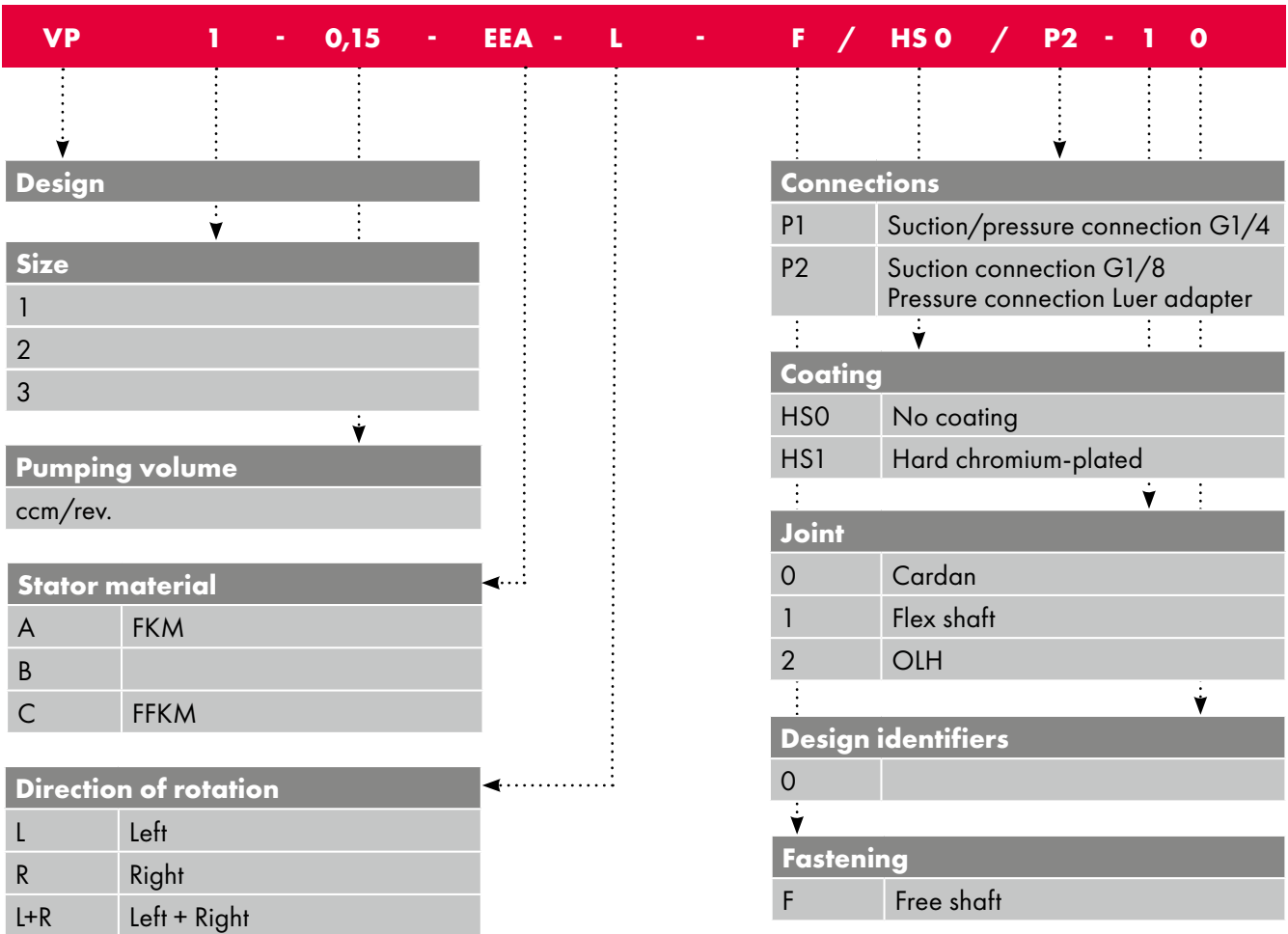

## 12. CERTIFICATE OF NON-OBJECTION

## SAFETY DECLARATION (CERTIFICATE OF NON-OBJECTION)

Last revised: 04/2023

Please reply to [reparaturen@beinlich-pumps.com](mailto:reparaturen@beinlich-pumps.com)

Pumps for which this safety certificate has not been completed and signed can neither be inspected nor repaired for safety reasons and will be returned unchecked at your expense.

Part no.		Serial no.	
Pump type			
Reason for return			
Pumped medium		Manufacturer	
Cleaning medium		Manufacturer	
Safety data sheet for the cleaning medium	<input type="radio"/> Yes*	<input type="radio"/> No	CAS no. <input type="text"/>
Safety data sheet for the pumped medium	<input type="radio"/> Yes*	<input type="radio"/> No	CAS no. <input type="text"/>

\*if positive, please enclose as an attachment

The pump was used in media which are hazardous to health/environment.	<input type="radio"/> No	<input type="radio"/> Yes
The pump was carefully emptied before dispatch and cleaned inside and outside.	<input type="radio"/> No	<input type="radio"/> Yes
Special safety measures or treatment is necessary or expected.	<input type="radio"/> No	<input type="radio"/> Yes

The pump, including accessories were last used with the following media:

If yes, which

Solvents	<input type="radio"/> No	<input type="radio"/> Yes	<input type="text"/>
Toxic liquids	<input type="radio"/> No	<input type="radio"/> Yes	<input type="text"/>
Biologically active liquids	<input type="radio"/> No	<input type="radio"/> Yes	<input type="text"/>
Radioactive liquids	<input type="radio"/> No	<input type="radio"/> Yes	<input type="text"/>
Corrosive liquids	<input type="radio"/> No	<input type="radio"/> Yes	<input type="text"/>
Alkali	<input type="radio"/> No	<input type="radio"/> Yes	<input type="text"/>
Explosive liquids	<input type="radio"/> No	<input type="radio"/> Yes	<input type="text"/>
Other media	<input type="radio"/> No	<input type="radio"/> Yes	<input type="text"/>

**SAFETY DECLARATION  
(CERTIFICATE OF NON-OBJECTION)**

Please reply to [reparaturen@beinlich-pumps.com](mailto:reparaturen@beinlich-pumps.com)

The undersigned assures that the above information is correct and complete and the shipping is carried out according to legal regulations. The undersigned is liable for all damages which arise as a result of the non-marked decontamination of the returned pump.

Beinlich expressly points out that repairs and verification work is carried out by trusting the correctness of the completion of this safety declaration (certificate of non-objection). Should physical injuries, death or even damage to property occur, claims for damages will be asserted.

<b>Company</b>	
<b>Street / Building no.</b>	
<b>Postcode / Town</b>	
<b>Phone</b>	
<b>Fax</b>	
<b>Email</b>	

**Contact**  
(in capitals)

**Date**

**Signature**  
(company stamp)

**Enclosed**

**beinlich**. *pump  
systems*

Beinlich Pumpen GmbH  
Gewerbestraße 29  
58285 Gevelsberg/Germany  
Phone +49 (0) 23 32 / 55 86 0  
info@beinlich-pumps.com  
www.beinlich-pumps.com



A company of  
**e.holding**  
FLUID TECHNOLOGY GROUP